

# Differential pressure measuring instrument

## testo 526 - Pressure measurement for all pressure ranges

---

Temperature-compensated differential pressure sensor  
0 to 2000 hPa in instrument

---

Additional 2 probe inputs for the connection of further probes for the measurement of pressure and temperature

---

Direct zeroing of display value from pressure probes

---

Display of Hold-, max. and min. values

---

Easy data storage by measurement site as well as analysis, archiving and documentation via optional PC software

---

Leakage rate measurement (pressure drop per time)

---

Testing of pressure drop in containers, pipelines etc.

---



hPa

°C

testo 526-1/-2 is a highly precise differential pressure measuring instrument with an internal sensor. This has a measuring range from 0 to 2000 hPa. The instrument is optimally suited to pressure checks in sensitive industrial processes, and is available in 2 accuracy classes.

- testo 526-1: accuracy 0.1 % of final value
- testo 526-2: accuracy 0.05 % of final value

The testo 526-1/-2 additionally has two probe inputs for the connection of further probes for the measurement of pressure and temperature. A large selection of probes is available for this purpose.

Specially for the purposes of tightness tests on containers, uninterrupted recording is possible via the test menu in testo 526-1 and testo 526-2. The subsequent processing of the measurement data via software or printout via the printer allow the documentation of the pressure test.

## Differential pressure measuring instrument

### testo 526-1

testo 526-1 (0 to 2000hPa 0.1% acc.) incl. battery and calibration protocol

Part no. 0560 5280



### testo 526-2

testo 526-2 (0 to 2000hPa 0.05% acc), fast coupling connection, battery and calibration protocol included

Part no. 0560 5281

testo 526-1 with internal sensor

0 to 2000 hPa / 0.1%

testo 526 is the ideal differential pressure meter for industrial applications. Processes can be accurately measured and monitored with an accuracy of 0.1% of the full-scale value.

testo 526-2 with highly accurate internal sensor 0 to 2000 hPa, 0.05%

testo 526 is the ideal differential pressure meter for sensitive industrial applications. Critical processes can be efficiently measured and monitored at an accuracy of up to 0.05% of the full-scale value.

## Advantages testo 526-1 and testo 526-2

- Built-in differential pressure probe
- 2 user defined probe sockets for pressure and temperature
- Wide selection of probes
- Documentation on site
- Easy data management via PC
- 2 line display with text menu guide
- Mains socket/fast battery recharging
- Fast-action coupling connections M8x0.5



Easy data management via PC



Inspection of transmitters with 4 to 20 mA interface



2 user defined probe sockets for pressure and temperature

## Further advantages testo 526-1 and testo 526-2

### Wide selection of probes

The differential pressure sensor is built into testo 526. Up to two additional probes can be connected via user-defined probe sockets.

- Differential pressure probes to 2000 hPa
- Absolute pressure probes to 2000 hPa
- Relative pressure probes to 400 bar
- Temperature probes from -200 to +1250 °C
- Probes for measuring current/voltage

### Documentation on site

- Measurement protocols can be printed on site. No awkward cables required on account of the infrared interface.
- Long-term legible thermal paper ensures that measurement data documentation can be stored for up to 10 years.

### Easy data management via PC

- The saved measurement data can be easily analysed and processed using the software available.
- Readings are taken by the instrument and can be depicted online by the software.
- Pressure drops can be protocolled online in cycles of 0.05 seconds in the Fast Measurement menu. Since, in most cases, pressure drops cannot be predicted, a rule can be defined via the trigger function; the pressure drops are then filtered out and stored separately for the user in indexed pages.

### Long-term monitoring made easy

- Measurement data can be saved separately or as a measurement series. The measurement rate (0.04 seconds, 1 second to 24 hours) and the number of values to be saved are freely selectable. The maximum memory size is 25000 readings.
- The readings are saved under separate names for the sites (max. 99 sites) - with retracing guarantee.
- Online measurement for large quantities of data can be activated via PC.

# Technical data

## General technical data testo 526-1/-2

Storage temperature	-20 to +70 °C
Operating temperature	0 to +50 °C
Power supply	Battery/Rechargeable battery, Mains unit 12 V
Battery type	9 V (6LR61)
Battery life	Continuous operation w/ internal pressure sensor: 30 h With rech. battery: 10 h With carbon battery: 18 h
Weight	300 g
Dimensions	219 x 68 x 50 mm
Housing material	ABS
Memory	100 kB (corresponds to approx. 25000 readings)

Connection	Hose: inner Ø 4 mm outer Ø 6 mm
Display	LCD display with symbol, 7 segment display and point matrix
Updating rate in display	2x per second, in fast measurement 4x per second
Measuring rate	from 0.04 seconds
PC	RS232 interface
Other features	Mains connection and battery recharging in instrument Automatic recognition of all connected probes 9 measurement units selectable: mbar, hPa, bar, Pa, kPa, inH <sub>2</sub> O, mmH <sub>2</sub> O, torr, psi
Warranty	2 years

## Sensor types





	<b>Piezoresistive pressure sensor</b>	<b>Ceramic sensor for external pressure probes</b>	<b>Piezoresistive pressure sensor For external pressure probes</b>	<b>NTC</b>	<b>Type K (NiCr-Ni)</b>
Measuring range	0 to 2000 hPa	-1 to 400 bar	0 to 2000 hPa	-40 to +150 °C	-200 to +1370 °C
Accuracy ±1 digit*	±0.1 % of fsv (testo 526-1) ±0.05 % of fsv (testo 526-2)	±0.2 % of fsv	±0.1 % of m.v.	±0.2 °C (-10 to +50 °C) ±0.4 °C (remaining range)	±0.4 °C (-100 to +200 °C) ±1 °C (remaining range)
Resolution	0.1 hPa	0.01 bar	0.1 Pa (0638 1347) 0.001 hPa (0638 1447) 0.01 hPa (0638 1547) 0.1 hPa (0638 1647; 0638 1847)	0.1 °C	0.1 °C
Static pressure	2000 hPa (abs)				
Overload	3000 hPa				
Zeroing	to 50 hPa				

\*Accuracy information applies only to instrument without probes connected

# Accessories

<b>Additional accessories and spare parts</b>	<b>Part no.</b>	
Desk-top power supply with international connection options	0554 1143	
9V rech. battery for instrument, instead of battery	0515 0025	
Recharger for 9V rechargeable battery, for external recharging of 0515 0025 battery	0554 0025	
<b>Transport and Protection</b>		
TopSafe (protection case), incl. carrier strap, bench stand and magnet. Protects instrument from dust, impact, scratches	0516 0446	
<b>Printer and Accessories</b>		
Testo fast printer IrDA with wireless infrared interface; 1 roll thermal paper; 4 AA batteries, for printing out measurements on site	0554 0549	
External fast charger for 1-4 AA rech. batteries, incl. 4 Ni-MH rech. batteries with individual cell charging and charge control display, incl. impulse trickle charging, integrated discharge function, with built-in international mains plug, 100-240 V, 300 mA, 50/60 Hz	0554 0610	
Spare thermal paper for printer (6 rolls), permanent ink, measurement data documentation legible for up to 10 years	0554 0568	
<b>Software and Accessories</b>		
ComSoft Professional, Pro software incl. data archiving	0554 1704	
RS232 cable, connects instrument to PC (1.8 m) for data transfer	0409 0178	
<b>Calibration Certificates</b>		
DAkkS calibration certificate/Pressure, Differential pressure, accuracy < 0.1 (% of full scale value)	0520 0205	
DAkkS calibration certificate/pressure, differential pressure, accuracy 0.1 to 0.6 (% of full-scale value)	0520 0215	
DAkkS calibration certificate/pressure, differential pressure, accuracy > 0.6 (% of full-scale value)	0520 0225	
ISO calibration certificate/Pressure, Differential pressure, accuracy < 0.1 (% of full scale value)	0520 0035	
ISO calibration certificate pressure, accuracy 0.1 to 0.6 (% of fsv), 5 points distributed over meas. range	0520 0025	
ISO calibration certificate pressure, accuracy > 0.6 (% of fsv)	0520 0005	
ISO calibration certificate/Pressure, Differential pressure, accuracy > 0.1 (% of fsv), for testo 521-2	0520 0405	
ISO calibration certificate/temperature, for air/immersion probes, calibration points -18°C; 0°C; +60°C	0520 0001	
ISO calibration certificate/temperature, meas. instr. with air/immersion probe; cal. points 0°C; +150°C; +300°C	0520 0021	
ISO calibration certificate/temperature, meas. instr. with surface probe; calibration points +60°C; +120°C; +180°C	0520 0071	
DAkkS calibration certificate/temperature, meas. instr. with air/immersion probe; calibration points -20 °C; 0 °C; +60 °C	0520 0211	
DAkkS calibration certificate/temperature, contact surface temperature probes; calibration points +100°C; +200°C; +300°C	0520 0271	
ISO calibration certificate/electrical	0520 1000	
<b>Probe accessories</b>		
Cable, 1.5 m long, connects probe with plug-in head to meas. instrument, PUR coating material	0430 0143	
Cable, 5 m long, connects probe with plug-in head to measuring instrument, PUR coating material	0430 0145	
Connection hose; silicone; length 5 m; max. load 700 hPa (mbar)	0554 0440	
Connection cable, 2.5 m long, for pressure probes 0638 1741/1841/1941/2041/2141	0409 0202	
Adapter to connect NiCr-Ni thermocouples and probes with open wire ends	0600 1693	



# Probes

Probe type	Illustration	Measuring range	Accuracy	Overload	Static pressure	Zeroing	Part no.
<b>Differential pressure probe</b>							
Precision pressure probe, 100 Pa, in robust metal housing with impact protection, incl. magnet for fast attachment, to measure differential pressure and flow speeds (in combination with Pitot tube)		0 to +100 Pa	$\pm(0.3 \text{ Pa} \pm 0.5\% \text{ of m.v.})$	50 hPa	100 hPa	to 20 Pa	0638 1347
Pressure probe, 10 hPa, in robust metal housing with impact protection incl. magnet for fast attachment, to measure differential pressure and flow speeds (in combination with Pitot tube)		0 to +10 hPa	$\pm 0.03 \text{ hPa}$	50 hPa	1000 hPa	to 0.4 hPa	0638 1447
Pressure probe, 100 hPa, in robust metal housing with impact protection, incl. magnet for fast attachment, to measure differential pressure and flow speeds (in combination with Pitot tube)		0 to +100 hPa	$\pm 0.5\% \text{ of m.v. (+20 to +100 hPa)}$ $\pm 0.1 \text{ hPa (0 to +20 hPa)}$	300 hPa	1000 hPa	to 4 hPa	0638 1547
Pressure probe, 1000 hPa, measures differential pressure, in robust metal housing with impact protection, incl. quick-closing coupling (M8 x 0.5), magnet for fast attachment		0 to +1000 hPa	$\pm 1 \text{ hPa (0 to 200 hPa)}$ $\pm 0.5\% \text{ of m.v. (200 to 1000 hPa)}$	2000 hPa	1000 hPa	to 20 hPa	0638 1647
<b>Absolute pressure probe</b>							
Pressure probe, 2000 hPa, measures absolute pressure, in robust metal housing with impact protection, incl. quick-closing coupling (M8 x 0.5), magnet for fast attachment		0 to +2000 hPa	$\pm 5 \text{ hPa (0 to +2000 hPa)}$	4000 hPa	–	–	0638 1847

Operating temperature: 0 to +50 °C (compensated)

Connection: Plug-in head, connection cable 0430 0143 or 0430 0145 required

# Probes

Probe type	Illustration	Measuring range	Accuracy	Overload	Zeroing	Part no.
<b>Relative pressure probe (media compatible)</b>						
Low pressure probe, refrigerant-proof stainless steel, up to 10 bar		-1 to +10 bar	±1% of fsv	25 bar	to 0.1 bar	0638 1741
High pressure probe, refrigerant-proof stainless steel, up to 30 bar		-1 to +30 bar	±1% of fsv	120 bar	to 0.3 bar	0638 1841

Operating temperature: -40 to +100 °C; 0 to +70 °C (compensated)

Connection: Plug-in head, connection cable 0409 0202 required  
screw-in thread 7/16" UNF

# Probes

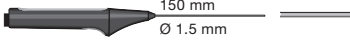
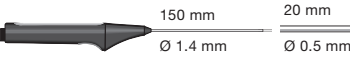
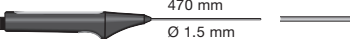
Probe type	Dimensions Probe shaft/probe shaft tip	Measuring range	Accuracy	t <sub>99</sub>	Part no.
<b>Temperature probes</b>					
Quick-action surface probe**	 150 mm Ø 10 mm	-200 to +300 °C	Class 2*	3 s	0604 0194
Super quick-action immersion/penetration probe for measurements in liquids **	 150 mm Ø 1.5 mm	-200 to +600 °C	Class 1*	1 s	0604 0493
Super quick-action immersion/penetration probe for measurements in gases and liquids with a low-mass tip**	 150 mm Ø 1.4 mm 20 mm Ø 0.5 mm	-200 to +600 °C	Class 1*	1 s	0604 9794
Super quick-action immersion/penetration probe for high temperatures **	 470 mm Ø 1.5 mm	-200 to +1100 °C	Class 1*	1 s	0604 0593

\*According to standard EN 60584-2, the accuracy of Class 1/2 refers to -40 to +1000/+1200 °C  
 \*\*Connection: Plug-in head. connection cable 0430 0143 or 0430 0145 required

	Part no.
Adapter to connect NiCr-Ni thermocouples and probes with open wire ends	0600 1693

0981 9824/msp/1/06.2017

Subject to change without notice.

