



EC-30C with four SR25.2 peristaltic pumps

Ultra Low Gas Cooler Series EC®

Version EC-30C with graphical display for easy navigation, dew-point -30 °C (~-22 °F), max. 250 NI/h sample flow rate

Special Features

- **Cooling capacity 130 kJ/h at maximum allowed ambient temperature**
- **250 NI/h max. sample gas flow rate**
- **Water vapour dew point input up to +70°C (+158 °F)**
- **Dew point output can be set from -20 °C to -30 °C (~-4 °F to ~-22 °F)**
- **Dew point output stability +/- 0.1 °C (+/- 0.18 °F)**
- **24/7 operation**
- **Icon-based graphical display for easy and intuitive navigation**
- **Safe operation guaranteed by self-monitoring and pre-warning messages to inform about upcoming maintenance work**
- **Service-friendly enclosure concept for 19" rack and wall mounting**
- **Better isolation materials to ensure over all low maintenance**
- **mA output configurable**
- **Separate relays for active deep-cooling unit (TKS), alarm and warning messages**
- **External humidity alarm (optional)**
- **Internal and external sample gas flow alarm (optional)**
- **Alarm message history with time stamps for more than 700 entries**
- **Jet-Stream heat exchangers**

Application

The patented M&C ultra-low cooler EC-30C is used in the gas analysis technique to reduce the dew point of humid sample gases, to provide a stable and very low dew point and reduce aerosol formation in the analyzer. The cooler EC-30C can be mounted near to the gas sample point to avoid costly energy consuming heated sample lines. Due to the extremely stable and low gas dew point, there are no water vapour cross-sensitivity and volumetric errors.

Description

The M&C gas cooler EC-30C is a two stage combination of compressor and Peltier cooler. The automatic defrost function of the dual deep freezer unit ensures 100 % availability during operation.

The micro processor-controlled electronics of the EC-30C in combination with the graphical display, offers a high degree of functionality, convenience in use, and safe operation.

The EC-30C is built for 24/7 hours of operating time. The cooling capacity of 130 kJ/h is constant, even under maximum allowed ambient temperature. A capacity reserve compensates parts of the natural ageing process and maximizes the service life of the EC-30C.

The pre-cooler unit is equipped with a Jet-Stream heat exchanger. The heat exchanger is cooled down to the constant temperature of +2 °C (35.6 °F) by a separate microprocessor controlled compressor cooling unit. The Jet-Stream heat exchanger in the pre-cooler unit removes a large amount of condensate, this ensures a safe and reliable pre-drying of the sample gas. An additional external vessel to separate the condensate is under normal conditions not necessary. The cooling unit of the pre-cooler dissipates the heat of the Peltier-elements.

The dual deep freezer unit is equipped with two modified Jet-Stream heat exchangers. Two separate pairs of Peltier-elements are cooling the heat exchangers down to a con-

stant temperature between -20 °C (~-4 °F) and -30 °C (~-22 °F). The factory setting is -30°C (~-22 °F).

The EC-30C switches automatically every 3 hours between the two deep freezer units. The deep freezer which is currently not in use, will be defrosted to prevent freezing of the heat exchanger and clogging of the gas lines.

The new graphical user interface is icon-based for easy and intuitive navigation. The messages are displayed in form of easy-to-understand icons.

Features like time stamps for the alarm message history, periodically self-monitoring and pre-warning messages to inform about upcoming maintenance work ensure a maximum degree of comfort, ease-of-use and safety to the operation of the EC-30C.

The smart periodically self-monitoring of the EC-30C, helps to plan upcoming maintenance and service work to prevent unnecessary down time.

A configurable mA-output is part of the EC-30C standard version.

Three optional peristaltic pumps SR-25.2 for automatic condensate removal can be installed into the unit.

An external humidity alarm, and an internal and external sample gas flow alarm can be ordered separately as an option.

A fourth optional peristaltic pump can be installed in combination with a second magnetic valve to provide permanently fresh sample gas to the inactive cooling unit. This makes sure that even in systems, where water vapour cross sensitivity exists, there are no visible peaks at switching of the dual deep freezer unit. This also prevents short peaks in the sample gas concentration due to stagnant gas.

Example application for EC-30C

- ① Heated filter sample probe SP2000-H
- ② Heated sample line 4M4/6
- ③ Ultra low cooler EC-30C
- ④ 3-way ball valves 3L/PV-1
- ⑤ Fine filter FP-2T-D with liquid alarm LA1
- ⑥ Full PTFE bellows pump MP-F
- ⑦ Aerosol filter CLF-5/W optional according to application
- ⑧ Analyzer, e.g. PMA1000
- ⑨ Flow meter FM 40, 25-250 NI/h
- ⑩ Option: Heat-exchanger purging with 4. peristaltic pump and magnet valve
- ⑪ Option: 3 peristaltic pumps SR25.2

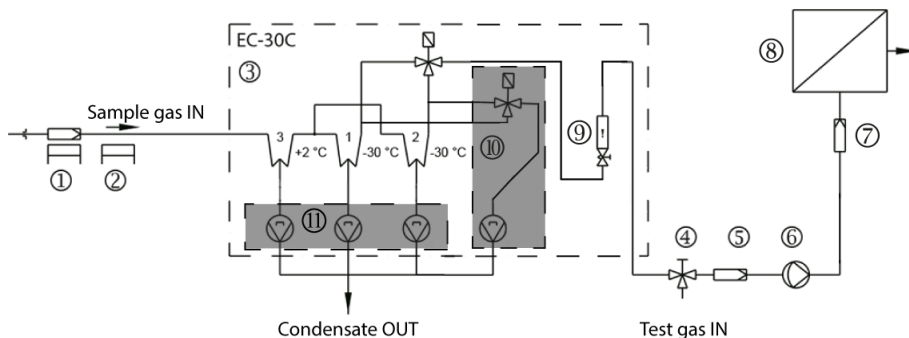

Schematic diagram of M&C heat-exchanger

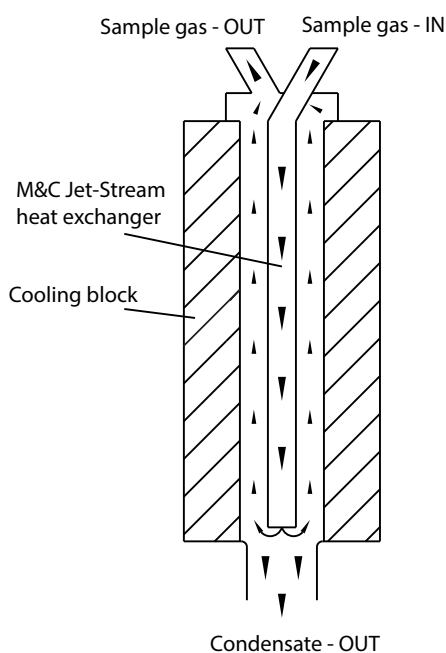

Max. possible water vapour dew point input [°C]* depending on flow rate and incoming gas temperature

Flow rate [l/h]	Incoming gas temperature [°C]				
	70 (158 °F)	90 (194 °F)	120 (248 °F)	150 (302 °F)	180 (356 °F)
90	70 (158 °F)	70 (158 °F)	69 (156.2 °F)	68 (154.4 °F)	67 (152.6 °F)
110	68 (154.4 °F)	67 (152.6 °F)	66 (150.8 °F)	65 (149 °F)	63 (145.4 °F)
130	65 (149 °F)	64 (147.2 °F)	63 (145.4 °F)	61 (141.8 °F)	59 (138.2 °F)
150	62 (143.6 °F)	61 (141.8 °F)	59 (138.2 °F)	58 (136.4 °F)	56 (132.8 °F)
170	59 (138.2 °F)	58 (136.4 °F)	56 (132.8 °F)	55 (131 °F)	53 (127.4 °F)
190	57 (134.6 °F)	56 (132.8 °F)	54 (129.2 °F)	52 (125.6 °F)	50 (122 °F)
210	55 (131 °F)	54 (129.2 °F)	52 (125.6 °F)	49 (120.2 °F)	46 (114.8 °F)
230	53 (127.4 °F)	52 (125.6 °F)	49 (120.2 °F)	47 (116.6 °F)	43 (109.4 °F)
250	52 (125.6 °F)	50 (122 °F)	47 (116.6 °F)	44 (111.2 °F)	41 (105.8 °F)

* This table shows the values of the max. possible water vapour dew point input depending on flow rate and incoming sample gas temperature. These values correspond to the max. cooling capacity of 130 kJ/h, and they must not be exceeded.

Technical Data

Cooler series EC*	Version EC-30C
Part No.:	02 K 6100 (a)*
Gas connection	tube connector DN 4/6
Condensate connections	3x tube connector GL25-12 mm
Material of sample contacting parts	Duran Glass, PTFE, PVDF
Single stream, gas flow rate	90 NI/h - 250 NI/h
Gas pressure	max. 3 bar abs.
Ambient temperature	+5 °C to +45 °C (+41 °F to +113 °F)
Storage temperature	-20 to +60 °C (~-4 °F to +140 °F)
Sample outlet dew point	-20 °C to -30 °C, default -30 °C (~-4 °F to ~-22 °F, default ~-22 °F)
Sample inlet temperature	max. 180 °C (+356 °F)
Water vapour dew point input	max. 70 °C (+158 °F)
Cooling capacity	max. 130 kJ/h** (at given input conditions)
Main power connection / Power consumption	230 V 50 Hz 380 VA or *Part No. ...-a = 115 V 60 Hz, 380 VA
Start up time	< 60 min.
Dead space	approx. 160 ml (5.41 fl. oz)
ΔP at 250 NI/h flow rate	5 mbar
Electrical connection	2.5 mm ² (0.0039 in ²) terminals, cable glands PG (1 x 12 mm, 2 x 16 mm, 2 x 20 mm) (1 x 0.47", 2 x 0.63", 2 x 0.79")
mA-output	0 - 20 mA / 4 - 20 mA, max. 500 Ohm load (including cable resistance),
Relais output alarm	1 changeover contact: 230 V AC 3 A, 24 V DC 3 A alarm: COM&NC closed No alarm: COM&NO closed
Relais output warning	1 NO contact, 24 V (AC/DC), 0.5 A warning: open
Relais output freezer units I and II	1 NO contact, 24 V (AC/DC), 0.5 A unit I on: closed unit II on: open
Case protection	IP20, EN 60529
Electrical equipment standard	EN 61010
Method of mounting	19" rack or wall mount
Case colour	RAL 9003
Dimension (w x h x d)	84 HP x 8U (with connections) x 360 mm (14.17")
Weight	39.1 kg (86.2 lbs)

* (a) Addition to the part number for EC-30C with 115 V

** For the given input conditions, please have a look at table: 'Max. water vapour dew point input [°C]* possible depending on flow rate and incoming gas temperature'.

Options

Options for EC-30C	
Part Number 01 P 9145	Peristaltic pump SR25.2, to mount at the front panel of the EC-30C
Part Number 03 F 3000	Aerosol-Filter CLF-5: External mounting in the outlet of an ultra low gas cooler EC-30C when sample tends to form aerosols. Technical data see data sheet 7.7 Fluid particle filter CLF-5
Part Number 02 K 9700 (a)*	Heat-exchanger purging: 4. peristaltic pump with magnetic valve
Part Number 02 K 9710	FM 40 (Flow meter, 25-250 NI/h)
Part Number 03 E 1001	LA 1S (Humidity sensor)
Part Number 02 E 3500	FA 20 (Flow sensor)

* (a) Addition to the part number for EC-30C with 115 V