



FP-70P190-D

Universal bypass filter series FP® for liquid filtration

Version FP-70P200-D, FP-70P190-D, FP-200P190-D

Special Features

- **Universal in use**
- **Simple construction**
- **Simple assembly and maintenance**
- **Condition of filterelement visible from outside**
- **Wall mounting**

Application

The M&C universal bypass filter is used in liquid analysis for filtration of low sample flow rates. Two different filtration methods are available:

In order to obtain the desired self-cleaning effect, the bypass filters FP-70 (200) P190-D should be operated with a minimum bypass quantity of 300 l/h.

1. Filter Type FP-70P200-D:
Filtration of a liquid flow in a settling area.
2. Filter Type FP-70 (200) P190-D:
Filtration of a liquid flow with self-cleaning effect through a bypass system with fast flow rate over the active filter surface.

Description

The basic construction of the bypass filter corresponds with the line of universal filters which are used for the gas filtration. The coarse sieve filter element is supplied with a pore size of 70 or 200 µm and is manufactured out of PP including the supporting pillar. The filter element is screwed into the filter head together with the filter element holder.

Through the glass filter body, the condition of the filter element is visible at any time without dismantling the filter. For changing the filter elements no tools are necessary.

The optimal positioning of the o-ring guarantees a safe sealing of the filter body to the filter head. The sample outlet may be turned around by 180 ° at the wall mounting bracket so that a flexible handling of the mountage is possible according to different local conditions. The sample connections are located in the filter head and in the lower part of the filter glass.

Respective tube connectors and GL25 adaptors DN4/6, 6/8, 8/10 or 10/12 are optionally available.

Dimensions

Filter FP-70P200-D Filtration in a setting area

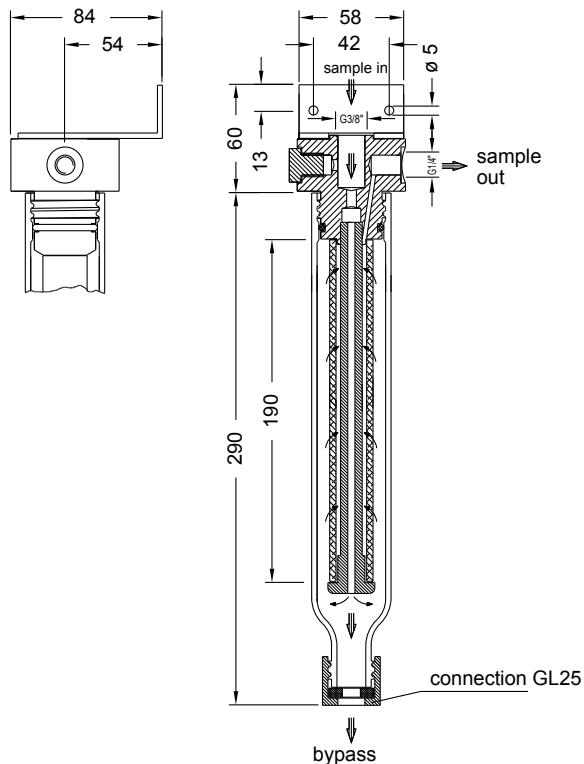

Dimensions in mm

Filter FP-70-P190-D / FP200P190-D Filtration with self-cleaning effect through bypass system

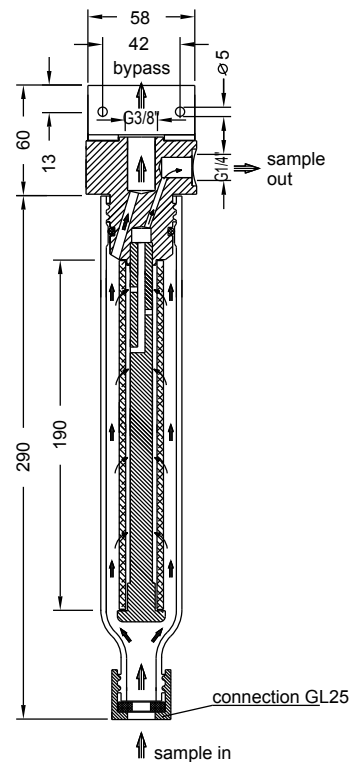

Flow rate in dependence of inlet pressure

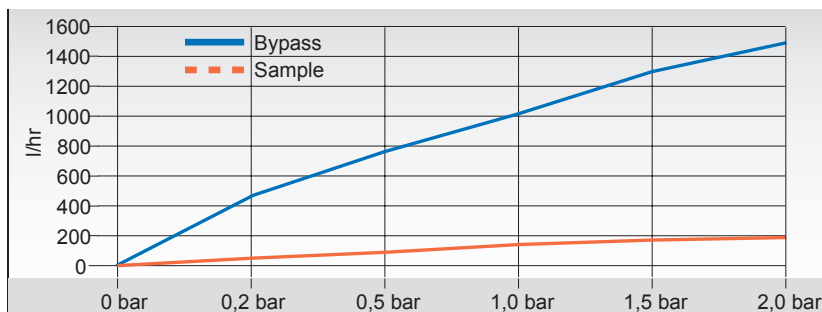

Technical Data

Liquid bypass filter series FP®	FP-70P200-D	FP-70P190-D	FP-200P190-D
Part No.	02F1400	02F1440	02F1450
Filtration in a settling area	yes	no	
Filtration with self-cleaning-effect	no	yes	
Filter element fineness	70 µm		200 µm
Bypass-connections	G3/8" i DIN ISO 228/1 and GL25-12 GL25-12 and G3/8" i DIN ISO 228/1		
Sample connection	G1/4" i DIN ISO 228/1		
Max. pressure at 20 °C	max. 2 bar abs. or max. 5 bar abs. with GL-connecting adapter		
Bypass flow max.	1500 l/hr		
Sample max.	180 l/hr		
Sample temperature max.	80 °C		
Ambient temperature max.	80 °C		
Filter surface	180 cm²		
Volume	100 ml		
Weight	approx. 650 g		
Method of mounting	wall mounting		
Material of sample contacting parts	PVDF, PP, glass, FPM		