



MP47-Z-BPR150

Analytical Diaphragm Pump

Series MP®

Version MP47-Z-BPR150
with integrated bypass admission pressure regulator

Special Features

- **With integrated bypass admission pressure regulator**
- **Corrosion resistant**
- **100% lubricant free**
- **Gas tight**
- **Maintenance free**
- **Long service life**

Application

The diaphragm pump MP47-Z-BPR150 is suitable for the 100 % oil-free delivery of corrosive gases with changing pressure conditions. The capacity and construction of the pump is especially designed for the problems in the analyze technique. The pump is gas-tight and operates without any maintenance.

Description

All sample contacting parts of the diaphragm pump MP47-Z-BPR150 are made of PTFE, PVDF and Viton or Kalrez. The lifted gas remains analytically pure due to the fact that the pump works absolutely without any lubricant. A special diaphragm and valve system guarantees a long life time and no maintenance is necessary. The pump is available for 230V or 115V.

One problem in the analyze technique, when lifting gases via filters, is that the filters are clogged after a longer period of time. This causes an increasing differential pressure above the filter and subsequently, a higher suction pressure for the pump is necessary. This, however, results in a decrease of the adjusted pump capacity.

In order to avoid this negative influence, the M&C diaphragm pump MP47-Z-BPR150 is equipped with a fully adequate bypass admission pressure regulator inside the pump head. Independent from the changing entry pressure, the bypass admission pressure regulator keeps the pressure at the pump outlet constant, so that the adjusted pump capacity resulting thereof remains constant as well.

For example, the entry pressure may vary from 0,46 bar abs. to 1,1 bar abs. for a pump capacity of 250Nl/h.

The outlet pressure is adjusted at works to 200mbar overpressure (adjustable up to 300mbar).

Technical Data

Diaphragm pump	MP47-Z-BPR150 -Viton, 230V	MP47-Z-BPR150 -Viton, 115V	MP47-Z-BPR150 -Kalrez, 230V	MP47-Z-BPR150 -Kalrez, 115V
Part No.	02 P 1160	02 P 1160a	02 P 1165	02 P 1165a
Voltage	230V 50Hz	115V 60Hz	230V 50Hz	115V 60Hz
Material of sample contacting parts	PTFE, PVDF, Viton		PTFE, PVDF, Kalrez	
Protection class	IP 20 - DIN 40050			
Pump capacity max.	6,6 l/min* in the range of adjustment (outlet pressure)			
Operating pressure max.*	1,1 bar abs.			
Operating pressure min.**	0,46 bar abs. for 250NI/h / 0,62 bar abs. for 400NI/h (outlet pressure 1,20 bar abs.)			
Outlet pressure	1,15 – 1,3 bar abs. / at works 1,20 bar abs.			
Gas temperature	-30 to +80°C			
Ambient temperature	-10 to +40°C			
Storage temperature	-15 to +60°C			
Power consumption	110W			
Current consumption	0,75A	1,7A	0,75A	1,7A
Gas connections	G1/4" i DIN ISO 228/1			
Electrical standard	EN 61010 part 1			
Weight	4,6 Kg			

* Maximum operating pressure for a constant outlet pressure and as a result a constant flow rate of the measuring gas.

** The minimum operating pressure that still guarantees a constant pump capacity is changing according to the necessary gas volume flow adjusted behind the pump and to the outlet pressure adjusted on the pressure regulator. The lower the necessary gas volume flow and the outlet pressure, the lower is the minimal possible operating pressure that still guarantees a constant outlet pressure and therefore a constant sample gas volume flow.

Pump head with integrated bypass admission pressure regulator

Bypass admission pressure regulator

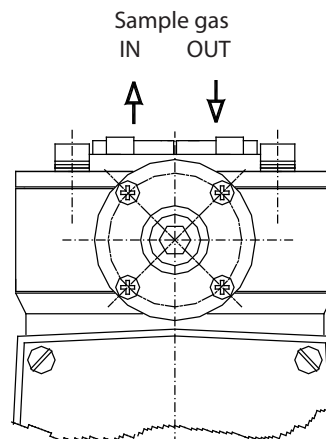
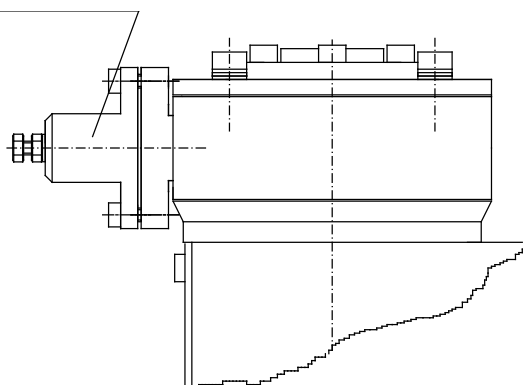

Dimensions

