

Demonstration board
MA 2067
Instruction manual
Version 1.4, Code no. 20 750 789

Distributor:

Producer:

METREL d.d.
Ljubljanska cesta 77
SI-1354 Horjul

Tel.: +386 1 75 58 200
Fax: +386 1 75 49 226
E-mail: metrel@metrel.si
<http://www.metrel.si>



Mark on your equipment certifies that this equipment meets the requirements of the EU (European Union) concerning safety and electromagnetic compatibility regulations.

© 2003 ... 2010 Metrel

No part of this publication may be reproduced or utilised in any form or by any means without permission in writing from Metrel

- 1. **Introduction**.....4
- 2. **Description of the demonstration board**.....5
 - 2.1 Front panel.....5
 - 2.2 Command part (back side of the demonstration board)7
 - 2.3 Demonstration board support.....8
- 3. **Technical data**.....8
- 4. **Connection to mains voltage**.....9
- 5. **List of possible measurements on the board**.....11
- 6. **Simulation of errors**.....13
- 7. **List of instruments to be used in combination with the board**.....15
- 8. **Maintenance**.....16
 - 8.1 Cleaning.....16
 - 8.2 Service16
- 9. **Standard set**.....17
- 10. **Options**17

1. Introduction

Demonstration board MA 2067 is a school facility. It simulates real low voltage electro-installation. Major elements like fuses, RCD protection switches, outlets etc. are incorporated.

The board is designed to be used in middle level electrical schools in order to improve practical and theoretical knowledge of listeners on electro-installation, on possible errors of installation and on how to carry out different measurements of electro-installation. It is aimed as well to be used at sale-demonstration rooms for presentation of electro-installation testers and their application.

Demonstration board enables demonstration on three earthing systems: TT, NT, IT. It performs the following major activities:

- Education of students / pupils on low voltage electro-installation.
- Practical training and courses about measurements on low voltage electro-installation and simulation of errors both, on electro-installation and on connected appliances.
- Demonstration on how to use different measurement instruments.

The board's plug is prepared to be connected to three-phase mains installation or to one-phase installation with help of one-phase adapter. The board can be used in horizontal position for small groups of listeners or in vertical position for demonstration in a class, presentation at seminar, exhibition etc.

2. Description of the demonstration board

2.1 Front panel

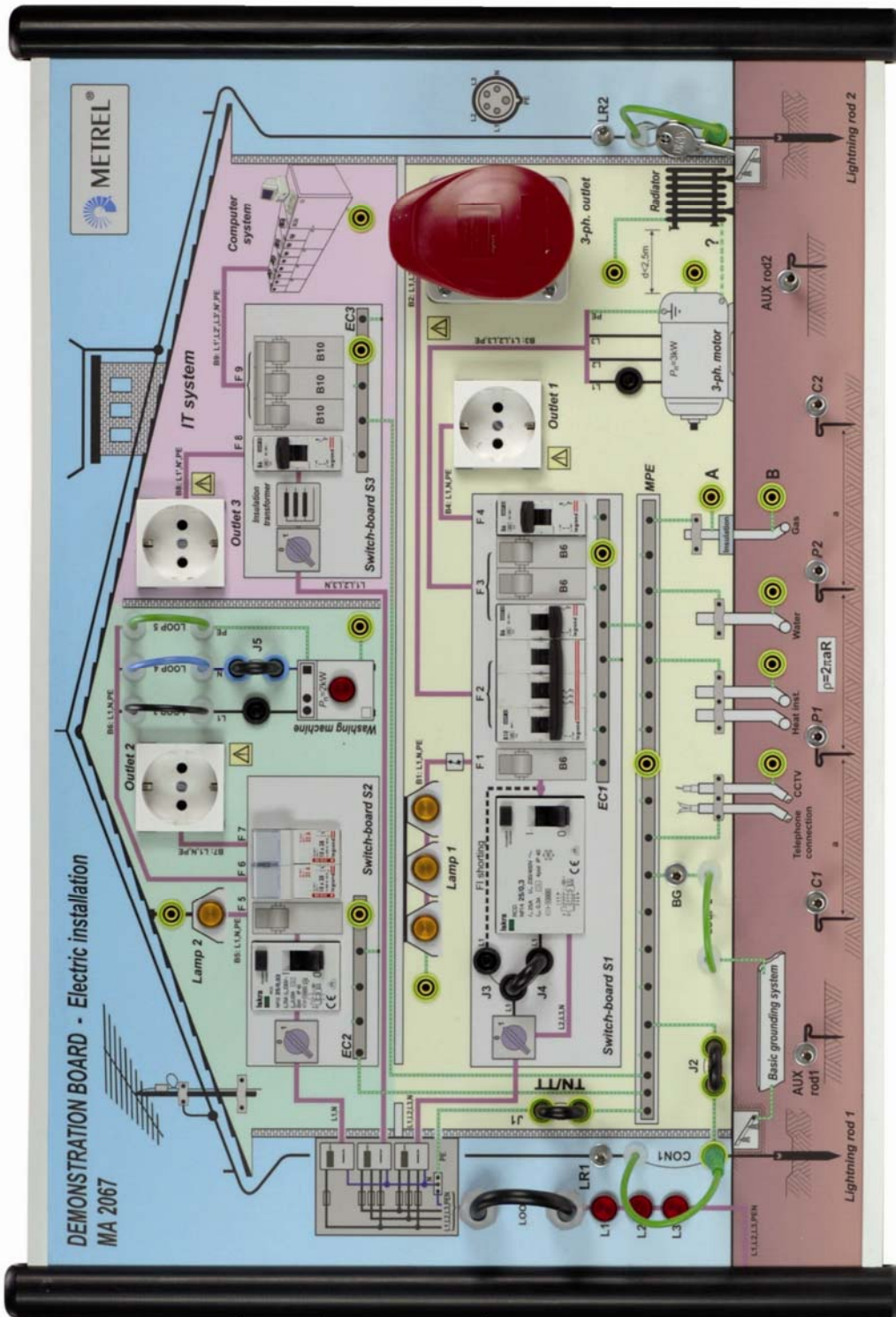

Fig.1. Front panel

Meaning of abbreviations on front panel

J1 to J5	Jumper 1 to Jumper 5
LR 1	L ightning r od 1
LR 2	L ightning r od 2
BG	B asic G rounding
AUX rod 1	AUX iliary r od 1
AUX rod 2	AUX iliary r od 2
C1	C urrent probe 1
C2	C urrent probe 2
P1	P otential probe 1
P2	P otential probe 2
MPE	M ain P otential E quilizing
EC1 to EC3	E arth C ollector 1 to E arth C ollector 3
F1	F use – L amp 1
F2	F use – 3 -phase outlet
F3	F use – 3 -phase motor
F4	F use – O utlet 1
F5	F use – L amp 2
F6	F use – W ashing machine
F7	F use – O utlet 2
F8	F use – O utlet 3
F9	F use – C omputer system
B1 to B9	B ranch 1 to B ranch 9

2.2 Command part (back side of the demonstration board)

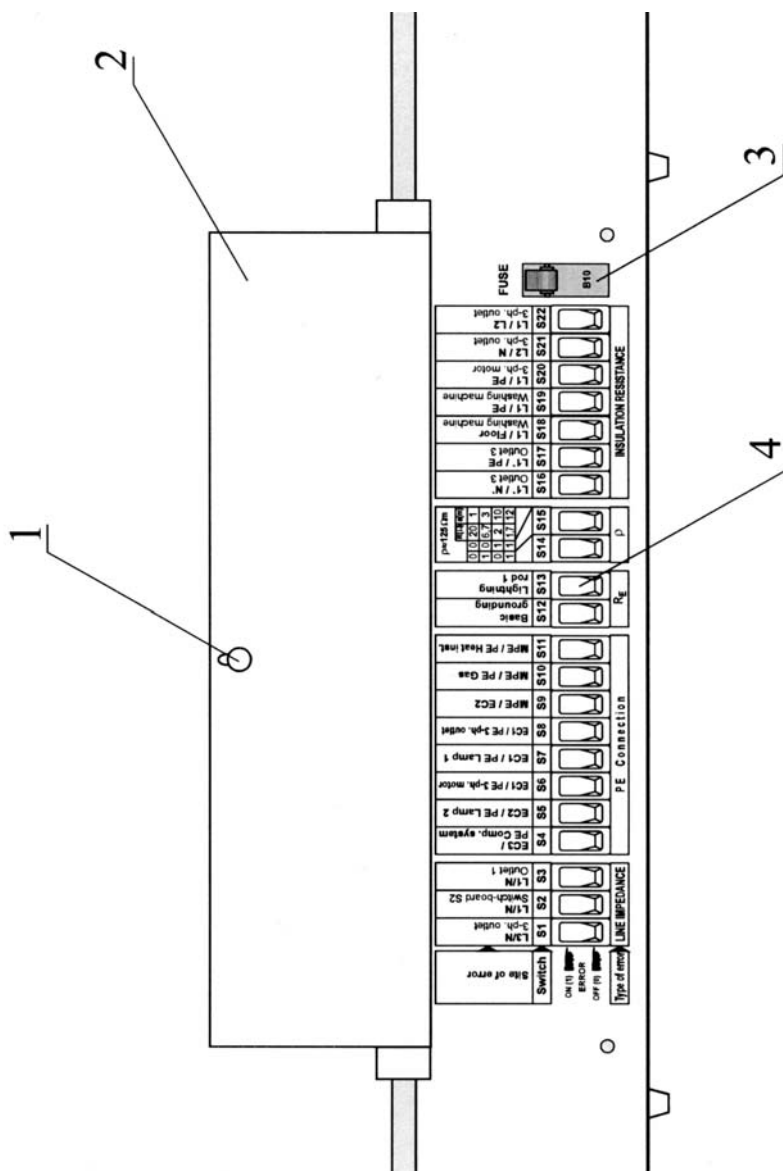

Fig.2. Command part (protection screen lifted up)

Legend:

- 1...Key lock for protection screen locking
- 2...Protection screen to cover command part
- 3...Automatic fuse which:
 - protects demonstration board and a user of the board in case of a fault on line L1 (simulated errors in command part excluded)
 - serves for general on/off of the board
 - serves for reset (reswitching on) of the board in case protection electronic inside the board trips the board due to a certain fault (simulated errors in command part excluded)
- 4...Switches for simulation of different errors

2.3 Demonstration board support

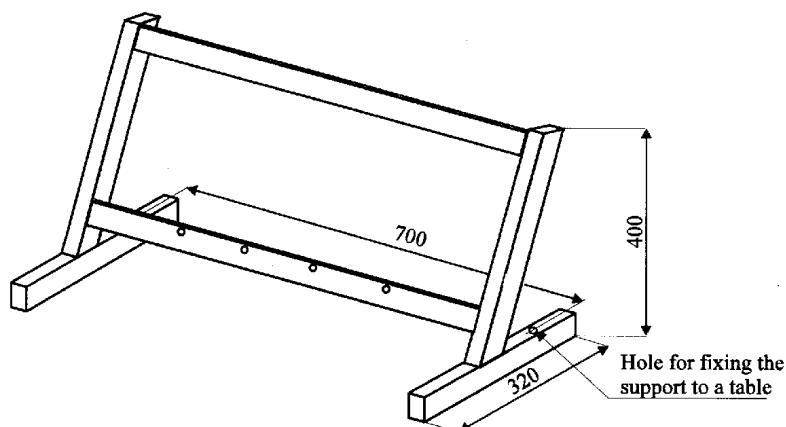

Fig.3. Support

Use the support in case demonstration board is to be used in vertical position for demonstration to a wider audience. It is possible to fix the support to a table using two screws (which are not a part of the standard set) in order to improve stability of demonstration board (when pulling out and pushing in test plugs).

3. Technical data

Mains connection	three-phase (4m) type 3P+N+PE or one-phase type, using one-phase adapter (2m)
Width	680 mm
Height	450 mm
Mass	12,5 kg approx.
Fixing to a table	by means of two screws (distance between fixing holes is 700 mm)
Respected standards	EN 61010-1 (safety) EN 50081-1 (EMC) EN 50082-1 (EMC) VDE 0100 (construction of electro-installation)
Test sockets	one-phase with PE terminal three-phase (3L+N+PE)
Protection classification	I (PE terminal connected to metal housing)

4. Connection to mains voltage

Before connecting the Demonstration board to mains installation, the following must be checked by the operator:

- That PE terminal is present at mains outlet which is to be used for connection of the board and that there are no damages noticed at the outlet (mechanical damages, broken contacts etc.)
- That there are no damages present at board's plug and at board itself (damaged outlets, mechanical damages of other elements etc.)
- That there is an RCD protection switch $I_{\Delta}=30\text{ mA}$ involved in mains installation to be used for supplying of the board (recommendation)

Attention!

- The board is allowed to be used only in presence of properly educated person-teacher, when using it in schools.
- Use only attached, original jumpers (defined distance between two ends) for carrying out required connections on front panel of the board.
- Use the test outlets on front panel for test purpose only and not for supplying different loads (radio, cooker, lamp etc.) because the components inside the board (wiring, switches, contacts, resistors etc.) are dimensioned for test purpose only.
- Do not short accessible contacts at one-phase or three-phase outlets.

Connection to 3-phase outlet

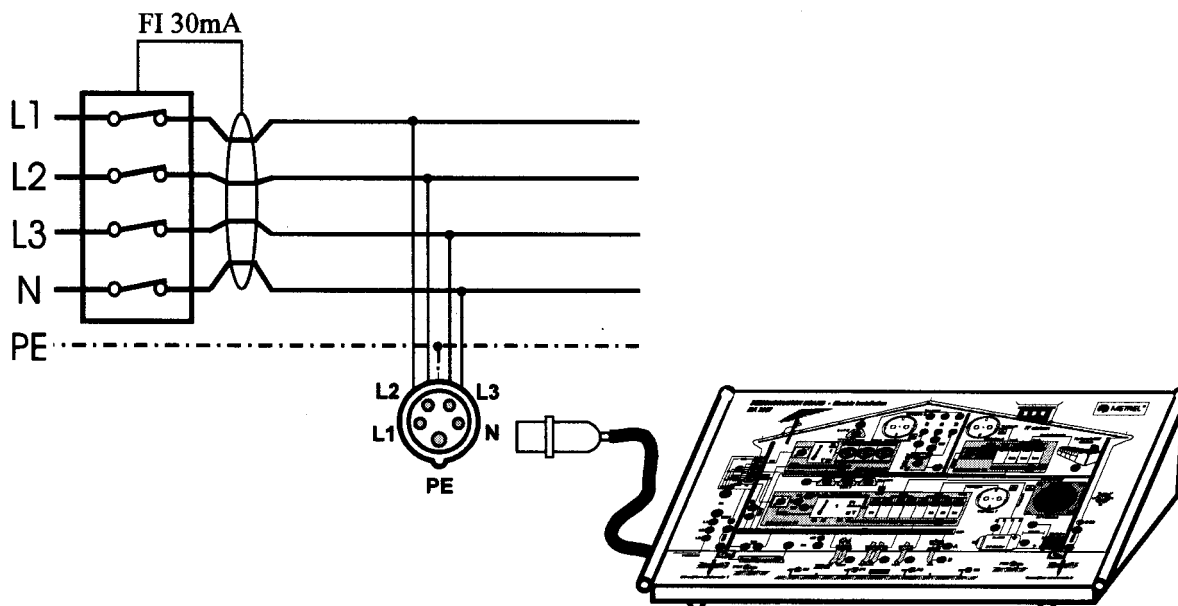

Fig.4. Connection of the Demonstration board to 3-phase outlet

Connection to one-phase outlet

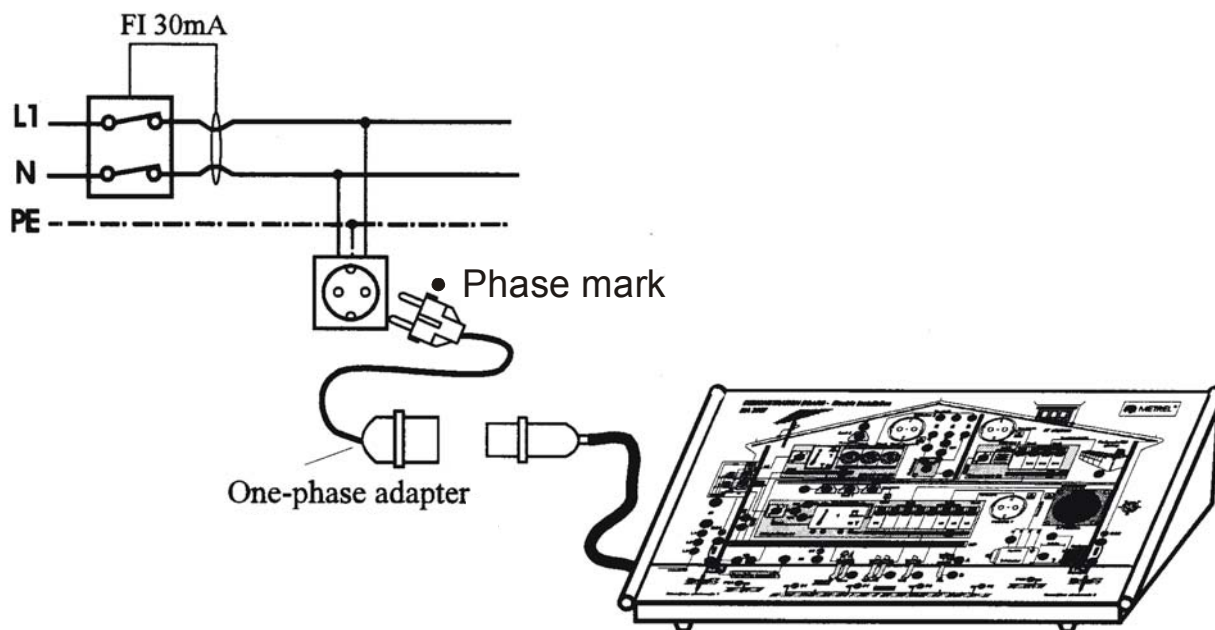
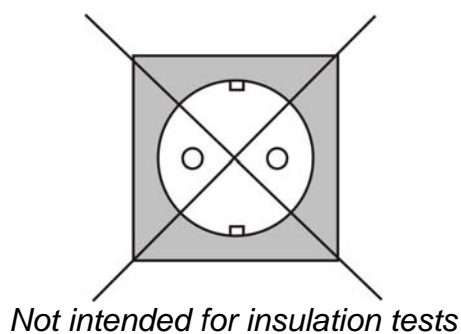

Fig.5. Connection of the Demonstration board to one-phase outlet



Note:

The equipment contains a special input protection circuit. Please ensure minimum of 10 s between unplugging the demo board and plugging it in again. This will enable that the protection circuit is working correctly.

5. List of possible measurements on the board

Insulation resistance between:

- Phase terminals on 3-ph. outlet
- Phase terminals/PE terminal on 3-ph. outlet
- Phase terminals/neutral terminal on 3-ph. outlet
- PE/neutral terminal on 3-ph. outlet
- Phase terminals/neutral terminal
- Phase terminals/PE terminal on one-ph. outlets
- PE/neutral terminal on one-phase outlets
- PE terminal/motor housing
- Phase terminal/washing machine housing
- Isolated installation/PE terminal on IT system

Connection between:

- MPE/gas installation
- MPE/isolated part of gas installation
- MPE/heat installation
- MPE/water installation
- MPE/shield of CCTV cable
- MPE/EC1
- MPE/EC2
- MPE/EC3
- EC1/PE terminal of outlet 1
- EC1/motor housing
- EC1/PE terminal of 3-ph. outlet
- EC1/lamp 1 housing
- EC2/lamp 2 housing
- EC2/washing machine housing
- EC2/PE terminal of outlet 2
- EC3/PE terminal of outlet 3
- EC3/computer system housing
- Motor housing/radiator

Earth resistance of:

- Basic grounding system with parallel connection of water and heat water installation (classic method)
- Basic grounding system (clamp method)
- Lightning system 1 (classic method)
- Lightning system 1 (clamp method)
- Lightning system 2 (classic method)
- Lightning system 2 (clamp method)
- Parallel connection of lightning systems 1 and 2 (classic method)

Ground resistivity:

- Distance **a** between test rods is 1 meter
- Distance **a** between test rods is 3 meters
- Distance **a** between test rods is 10 meters
- Distance **a** between test rods is 12 meters

Line impedance between:

- Phase/neutral terminals on outlet 1
- Phase/neutral terminals on outlet 2
- Phase/neutral terminals on outlet 3
- Phase terminals/neutral terminal on 3-ph. outlet
- Phase terminals on 3-ph. outlet (in case the board is connected to 3-ph. mains installation)

Loop impedance between:

- Phase/PE terminals on outlet 1
- Phase/PE terminals on outlet 2
- Phase terminals/PE terminal on 3-ph. outlet

Phase rotation:

- On 3-ph. outlet (in case the board is connected to 3-ph. mains installation)

Leakage current:

- Into PE terminal on washing machine connection (clamp method-loop 5)
- From washing machine to floor (clamp method-loop 3, loop 4, loop 5)
- Of whole installation (clamp method-loop 1)
- Into basic grounding system (clamp method-loop 2)

Trip out time and tripping current of 300mA RCD protection switch:

- On outlet 1
- On 3-ph. outlet

Trip out time and tripping current of 30mA RCD protection switch:

- On outlet 2

Contact voltage U_B :

- On PE terminal of outlet 1
- On motor housing
- On radiator
- On lamp 1 housing

-
- On PE terminal of outlet 2
- On washing machine housing
- On lamp 2 housing

Mains voltage and frequency of the voltage between:

- Phase terminals on 3-ph. outlet
- Phase terminals/neutral terminal on 3-ph. outlet
- Phase terminals/neutral terminal on one-phase outlets

6. Simulation of errors

It is possible to demonstrate 19 different errors and also their combinations. There are error switches in the command part of the board, that can switch **on** errors described nearby the switches (see fig.2).

Value of measurement parameters in case switch is in **on** or in **off** position see in the table below.

List of possible error simulations on electro-installation

Simulated error		Conditions for measurement	Measurement			
Switch No.	Place of simulated error		Measured parameter	Test points	Measured value (ERROR ON)	Measured value (ERROR OFF)
Line impedance						
S1	L3/N (3-ph. outlet)	FI 300 mA switched on, F2 switched on	Z LINE	L3/N (3-ph. outlet)	> 10Ω	< 2Ω
S2	L1/N (Switch-board S2)	FI 30 mA switched on, F7 switched on	Z LINE	L1/N (Outlet2)	> 10Ω	< 2Ω
S3	L1/N (Outlet1)	FI 300 mA switched on, J4 inserted	Z LINE	L1/N (Outlet1)	> 10Ω	< 2Ω
*	L1'N' (Outlet3)	FI 30 mA switched on, F8 switched on	Z LINE	L1'N' (Outlet3)	approx. 100Ω	
PE of fault loop						
S4	EC3/PE Comp. system	/	R	EC3/PE Comp. system	> 20Ω	< 1Ω
S5	EC2/Lamp2	/	R	EC2/PE Lamp2	approx. 2.7Ω	< 1Ω
S6	EC1/PE 3-ph. motor	/	R	EC1/PE 3-ph. motor	approx. 3.3Ω	< 1Ω
		J3 inserted, F3 switched on, J1 inserted, J2 inserted, CON1 inserted, CON2 inserted	Z LOOP	L1/PE (3-ph. motor)	> 3.3Ω	< 2Ω
S7	EC1/PE Lamp1	/	R	EC1/PE Lamp1	>20Ω	< 1Ω
S8	EC1/PE 3-ph. outlet	/	R	EC1/PE 3-ph. outlet	approx. 3.4Ω	< 1Ω
		J3 inserted, F2 switched on, J1 inserted, J2 inserted, CON1 inserted, CON2 inserted	Z LOOP	L1/PE (3-ph. outlet)	> 3.4Ω	< 2Ω
S9	MPE/EC2	/	R	MPE/EC2	approx. 2.2Ω	< 1Ω
S10	MPE/Gas	/	R	MPE/PE Gas	approx. 3.3Ω	< 1Ω
S11	MPE/Hot water	/	R	MPE/PE Hot water	approx. 3.3Ω	< 1Ω
Earth resistance error						
S12	Basic grounding system	J1 pulled out, J2 pulled out	R _E (classic meth.)	BG/AUXrod1/AUXrod2	approx. 250Ω (parallel water)	approx. 10Ω
			R _E (current clamp meth.)	BG/AUXrod1/AUXrod2, LOOP2	approx. 500Ω	
S13	Lightning rod 1	CON1 inserted, CON2 pulled out, J2 pulled out	R _E (classic meth.)	LR1/AUXROD1/AUXROD2	approx. 100Ω	approx. 4.7Ω
			R _E (current clamp meth.)	LR1/AUXROD1/AUXROD2		
Insulation error						
S16	L1'N' (Outlet3)	F8 switched off	R _{ISO}	L1'N' (Outlet3)	approx. 0.45MΩ	> 200MΩ
S17	L1'/PE (Outlet3)	F8 switched on	I _{PEL} and I _{PEV}	L1'/EC3	approx. 2.3mA	< 1 mA
S18	L1/Floor (Washing machine)	FI 30 mA switched on, F6 inserted, J5 inserted	I _Δ	LOOP3,	approx. 5.1mA	< 3.5mA
S19	L1/PE (Washing machine)	J5 pulled out, F6 not inserted	R _{ISO}	L1/PE (Washing machine)	approx. 0.45MΩ	> 200MΩ
S20	L1/PE (3-ph. motor)	F3 switched off	R _{ISO}	L1/PE (3-ph. motor)	approx. 0.45MΩ	> 200MΩ
S21	L2/N (3-ph. outlet)	F2 switched off	R _{ISO}	L2/N (3-ph. outlet)	approx. 0.45MΩ	> 200MΩ
S22	L1/L2 (3-ph. outlet)	F2 switched off	R _{ISO}	L1/L2 (3-ph. outlet)	approx. 0.45MΩ	> 200MΩ

*----irrespective of switches' state

Ground resistivity

Selected value of resistance R and distance a			Ground resistivity (Ωm)	Test points
Switch S14	Switch S15			
OFF	OFF	R= 20Ω, a= 1m	approx. 125	C1, P1, P2, C2
ON	OFF	R= 6.7Ω, a= 3m		
OFF	ON	R= 2Ω, a= 10m		
ON	ON	R= 1.67Ω, a= 12m		

7. List of instruments to be used in combination with the board

In order to avoid any damage on the Demonstration board or on test instrument which is used in combination with the board, it is advisable to use the following instruments for carrying out the measurements:

- **EurotestXA** MI 3105
- **EurotestAT** MI 3101
- **EurotestXE** MI 3102
- **EurotestCOMBO** MI 3125B
- **EurotestLITE** MI 3002
- **EurotestEASI** MI 3100
- **EurotestXA** MI 3105
- **EurotestCOMBO** MI 3125
- **Eurotest 61557** MI 2086
- **Instaltest 61557** MI 2087
- **Earth-Insulation Tester** MI 2088
- **Smartec Insulation / Continuity** MI 3121
- **Smartec Z Line – Loop / RCD** MI 3122
- **Smartec Earth / Clamp** MI 3123
- **Smartec RCD Loop / Line** MI 2120
- **Smartec Insulation / Continuity** MI 2123
- **Smartec Earth / Clamp** MI 2124
- **Installcheck** MI 2150

For other instruments please consult the producer of the board.

8. Maintenance

8.1 Cleaning

Use soft patch slightly moistened with water or alcohol to clean the surface of the **Demonstration board** and leave it to dry totally after the cleaning.

Do not use liquids based on petrol!

Do not spill cleaning liquid over the instrument!

8.2 Service

In case of any board malfunction or if there is any damage noticed at the board, the board must be serviced by a competent service department. Contact your dealer or producer of the board for further information.

There are no customer replaceable components at the board (except two fuses (F6 and F7 type D01 6A) on front panel)!

Producer's address:

METREL d.d.
Ljubljanska 77
SI-1354 Horjul
Tel.: +386 1 755 82 00
Fax.: +386 1 754 92 26
<http://www.metrel.si>;
E-mail:metrel@metrel.si

9. Standard set

- Demonstration board
- Jumper, 4pcs

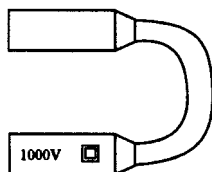

- Board support for vertical use

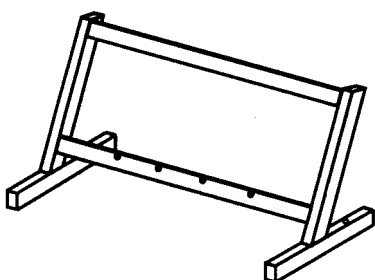

- Three phase to one phase adapter

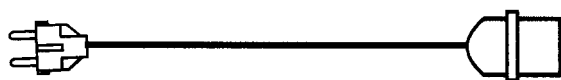

- Instruction manual
- Booklet with exercises

10. Options

- Fuse D01 6A.....code 83002465
- Jumper.....code 83002466

