



CE MultiTester **MI 2094** **User Manual**

Version 3.8, Code No. 20 751 557

Distributor:

Manufacturer:

METREL d.d.
Ljubljanska cesta 77
1354 Horjul
Slovenia

web site: <http://www.metrel.si>

e-mail: metrel@metrel.si

Version note: this manual relates to MI2094 HW3.



Mark on your equipment certifies that this equipment meets the requirements of the EU (European Union) concerning safety and interference causing equipment regulations

© 2002...2013 METREL

No part of this publication may be reproduced or utilized in any form or by any means without permission in writing from METREL.

1. General presentation	5
1.2. Warnings and notes.....	5
1.3. Warranty.....	6
1.4. List of measurements carried out by the instrument.....	7
1.5. List of applicable standards.....	7
2. Description of the instrument	8
3. Technical specifications	10
3.1. Withstanding test (PROG.HV and HV position).....	10
3.2. Burn out (HV position).....	11
3.3. Low resistance (Continuity position).....	11
3.4. Voltage drop scaled to 10 A~ (option in Continuity position).....	12
3.5. Insulation resistance.....	13
3.6. PE leakage current.....	13
3.7. Substitute leakage current.....	14
3.8. Touch leakage current.....	14
3.9. Functional test.....	15
3.10. Discharge time (DISC.TIME position).....	16
3.11. General.....	16
4. Measurements	18
4.1. Withstanding test:.....	18
4.2. Withstanding test with preset voltage/time diagram:.....	23
4.3. Low resistance test with currents of 0.1A / 0.2A / 10A / 25A~.....	26
4.4. Voltage drop scaled to test current of 10 A~.....	29
4.5. Insulation resistance.....	30
4.6. Discharge time - external (input MAINS TEST).....	33
4.7. Discharge time-internal.....	35
4.8. Leakage current.....	38
4.9. Substitute leakage current.....	39
4.10. Touch leakage current.....	41
4.11. Functional test.....	42
4.12. Autotest.....	44
5. Operation	49
5.1. Warnings.....	49
5.2. Results memory.....	50
5.3. Recalling of stored results.....	52
5.4. Communication.....	53
5.4.1. RS232 interface.....	53
5.4.2. Transferring the stored data to PC.....	53
5.5. System configuration.....	54
5.6. Contrast of the display.....	58
5.7. Use of remote control pedal.....	59
5.8. Use of WARNING LAMP.....	60
5.9. Use of barcode reader.....	61
5.10. Use of EXT/DOOR input.....	61
5.10.1. DOOR input.....	62
5.10.2. EXTERNAL input.....	62

6. Maintenance	65
6.1. Metrological check.....	65
6.2. Service	65
6.3. Cleaning	65
6.4. Replacing the fuses (properly trained service personnel only!)	65
7. PC Software - CE Link	67
7.1. Installing CE Link.....	67
7.2. Introduction notes	67
7.3. Download data.....	69
7.4. Open data file	72
7.5. Printing documents.....	74
7.5.1 Printing selected rows	74
7.5.2 Print separately.....	76
7.6. Header programming.....	77
7.7. Sequence editor	78

1. General presentation



1.2. Warnings and notes

In order to reach high level of operator’s safety while carrying out various tests and measurements using CE Multitester, as well as to keep the test equipment undamaged, it is necessary to consider the following general warnings:

- If the test equipment is used in a manner not specified in this user manual the protection provided by the equipment might be impaired!
- Read this instruction manual carefully, otherwise use of the instrument may be dangerous for the operator, for the instrument or for equipment under test!
- Use only grounded mains outlets to supply the instrument!
- Do not use any damaged mains outlet or damaged mains connection cable!
- A competent authorized person must only carry out Service or calibration procedure!
- Only a skilled person, who is familiar with hazardous voltage operations, can handle CE MultiTester!
- Disconnect all unused test leads before starting measurement; otherwise the instrument can be damaged!
- In case of failure of the instrument test results may be impaired. It is a good practice to regularly confirm/check the accuracy of the tester (by simple field calibration, comparison to known reference values etc).

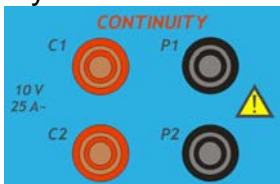

Meaning of signs on front panel:

<p>Insulation section</p> 	<p>Dangerous voltage may be present; measurements shall be carried out only on de-energized object</p>
<p>Continuity section</p> 	<p>Measurements shall be carried out only on de-energized object. Read instructions on how to replace blown-up fuse.</p>
<p>Withstanding section</p> 	<p>Dangerous voltage may be present. Switch off the instrument immediately if the red warning lamp (fig. 1., pos. 22) does not light after switching on HV generator, and service the instrument. Always handle as the test leads are energized.</p>

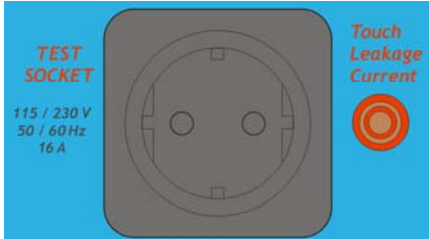
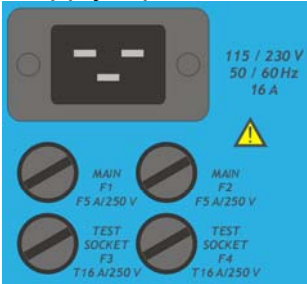
<p>Function test section</p> 	<p>Dangerous voltage is present on the TEST SOCKET (fig.1, pos.11) after pressing the START/STOP push button.</p>
<p>Power supply input</p> 	<p>Dangerous voltage is present on the fuses. Switch off the instrument and disconnect all test cables and mains cord before replacing the fuses or opening the instrument.</p>

Notes!

For correct operation of the instrument fuses F3 and F4 must be in good condition because the test socket is the point from which the instrument observes the input voltage (zero crossing for soft start of internal generator).

	<p>The CE Multitester enables connection to supply systems other than TN or TT types. For this reason earth control can be disabled (see chapter 5.5. System configuration). With the disabled earth control, the instrument warns each time when it is powered on with the message.</p> <p>Warning! The instrument must be properly grounded!</p>
---	---

1.3. Warranty

Unless stated differently, our instruments are guaranteed against any manufacturing or material defect. They do not bear the specification known as the safety specification. Our guarantee, which may not under any circumstances exceed the amount of the invoiced price, is for the repair of our faulty equipment only, carriage paid to our workshops. It is applicable for normal use of our instruments and does not apply to any damage or destruction caused, notably by error in mounting, mechanical accident, faulty maintenance, defective use, overload or excess voltage.

Our responsibility is strictly limited to the pure and simple replacement of the faulty parts of our equipment; the buyer expressly renounces any attempt to find us responsible for damages or losses caused directly or indirectly.

1.4. List of measurements carried out by the instrument

- Withstanding programmed voltage - time sequence test
- Withstanding voltage test
- High voltage burn-out test
- Continuity test
- Voltage drop test
- Insulation resistance test
- Leakage current tests (leakage, substitute, touch)
- Functional tests (power, voltage, current, $\cos \varphi$, frequency)
- Discharge time measurement

1.5. List of applicable standards

CE MultiTester is designed in accordance with the following standards:

- EN 61010-1safety
- EN 61326-1electromagnetic compatibility
- EN 61557-2insulation resistance measurement
- EN 61557-4continuity measurements

Measurements in compliance with:

- EN 60204-1Electrical equipment of machines
- EN 60335-1Household and similar electrical appliances
- EN 61439-1Switch-gear and control-gear assemblies
- EN 60598-1Luminaries
- IEC 60745Hand-held motor-operated tools
- IEC 60755Residual current operated protect. devices
- EN 60950Safety of information technology equipment
- EN 61010-1Safety requirements for electrical equipment
- IEC 61029Transportable motor-operated tools
- EN 61558-1Transformers and power supply units
- EN 60065Audio, video, and similar electronic apparatus
- VDE 701 T1Repair and modification inspections
- VDE 702 T1Repeat tests of electrical appliances

Measurements according to standards above are possible only up to 16 A (maximum power capability of the CE MultiTester).

2. Description of the instrument

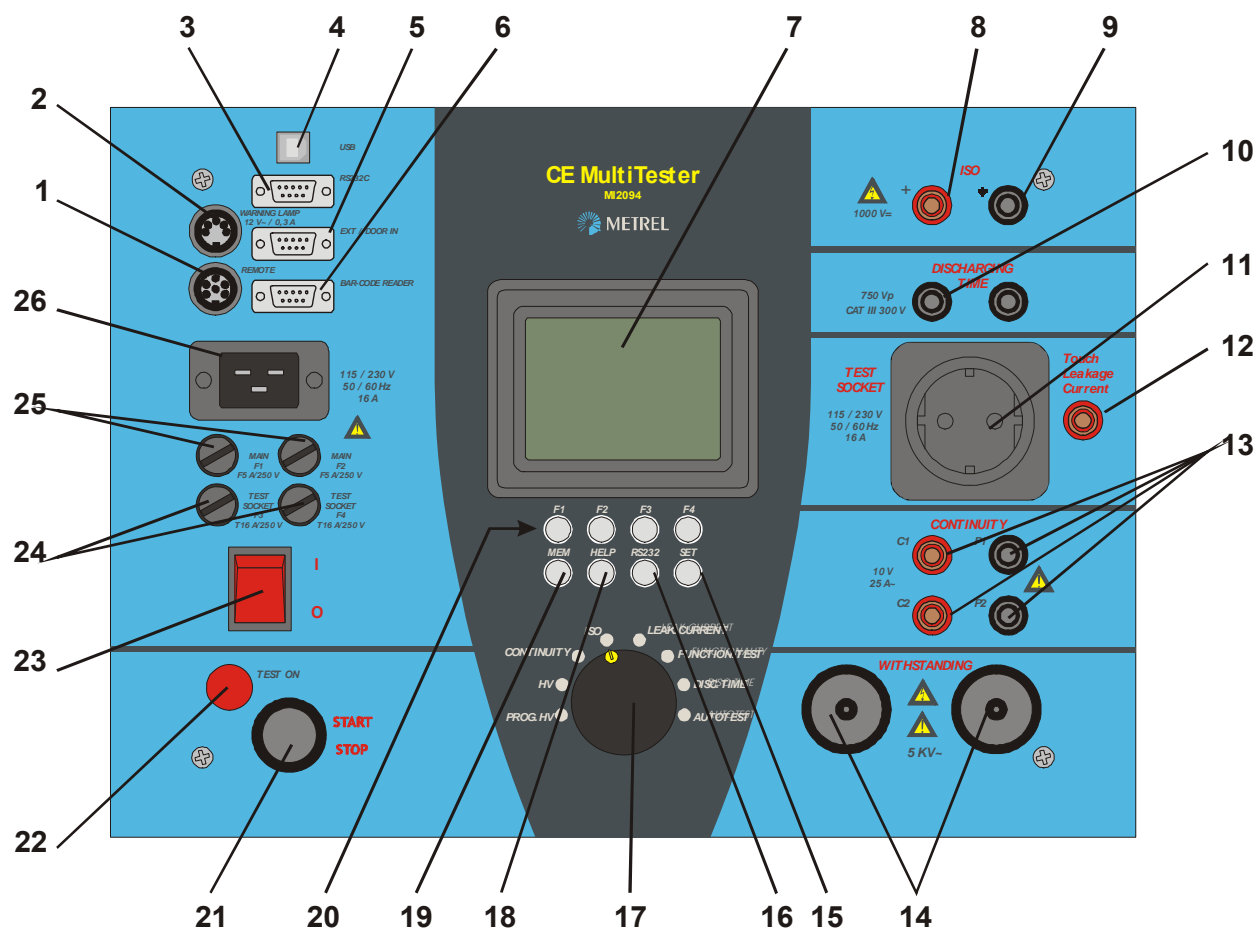

Fig.1. Front panel layout

Legend:

- 1..... **REMOTE** connector to connect REMOTE CONTROL PEDAL
- 2..... **WARNING LAMP** connector to connect WARNING LAMP
- 3..... **RS 232** connector to connect external printer or PC
- 4..... **USB** connector to connect PC
- 5..... **EXT/DOOR IN** connector
- 6..... **BAR CODE READER** connector
- 7..... **LCD** dot matrix display with continuous backlight
- 8..... Positive **INSULATION** test terminal
- 9..... Grounded **INSULATION** test terminal
- 10.... **DISCHARGE TIME** test terminals
- 11.... **TEST SOCKET 230V /16A**
- 12.... **TOUCH LEAKAGE** test terminal
- 13.... **CONTINUITY** test terminals (current test terminals C1, C2, and potential test terminals P1, P2)
- 14.... **WITHSTANDING** test terminals

15.... **SET** key (press when the instrument is switched ON):

- Set date / time
- Set serial port settings
- Set barcode reader baud rate
- Clear records memory
- Clear devices / records
- Clear program memory
- Load default setting
- INPUT DOOR IN disabled / enabled
- EARTH CONTROL disabled / enabled

16.... **RS232** key:

- Enter communication mode
- Transmit memorized data to PC

17.... **ROTARY SWITCH** to select desired function

18.... **HELP** key:

19.... **MEM** key:

- Memorize results
- Recall memorized results

20.... General keys F1 to F4 (function of each key is shown on display)

21.... **START/STOP** push button

22.... **TEST ON** warning lamp

23.... **POWER ON/OFF** switch with indication lamp

24.... T16A 250V 6.3x 32 fuses protect test socket from overloading

25.... F 2.5A 250V fuses protect instrument power supply

26.... Mains connector

3. Technical specifications

3.1. Withstanding test (PROG.HV and HV position)

Nominal test voltage: adjustable 100 V ÷ 5000 V / 50 Hz, 60 Hz at
 $U_{\text{mains}} = 115 \text{ V} / 230 \text{ V}$, $P_{\text{load}} = 500 \text{ VA}$
 Open circuit test voltage: U_n (nominal test voltage) (- 5 V / +10 %)
 at $U_{\text{mains}} = 115 \text{ V} / 230 \text{ V}$
 Differential output:..... 2 HV plugs
 Voltage shape: sinusoidal

Test voltage readout

Range (kV)	Resolution (kV)	Accuracy
0.100 ÷ 0.999	0.001	±(2 % of reading + 5 dig.)
1.000 ÷ 5.000	0.001	±(3 % of reading + 5 dig.)

Two different voltage procedure modes:

- Standard voltage mode
- Programmable voltage mode (parameters t_1 , t_2 , t_3 , U_1 , U_2)

Trip-out test current for nominal test voltages up to 1000 V adjustable to 0.5*, 1.0*, 1.5, 2.0, 2.5, 3.0, 3.5, 4.0, 4.5, 5.0, 5.5, 6.0, 6.5, 7.0, 7.5, 8.0, 8.5, 9.0, 9.5, 10, 20, 30, 40, 50, 60, 70, 80, 90, 100, 150, 200, 250, 300, 350, 400, 450, 500 mA.

* except in Autotest

For test voltages greater than 1000 V maximum current limit depends on max high voltage power characteristic (500 VA = max. power).

Accuracy of trip-out test current:±10 % of set value.

Test current readout (sin wave)

Range (mA)	Resolution (mA)	Accuracy
*0.0 ÷ 500.0	0.1	±(5 % of reading + 5 digit) absolute value
0.0 ÷ 500.0	0.1	±(30 % of reading +10 digit) resistive or capacitive value**

* (1.5 – 500) mA in Autotest

** not displayed at 'Trip out' STOP

Absolute value of test current is always displayed ($I_A = \sqrt{I_R^2 + I_C^2}$) together with selected resistive (⇔) or capacitive (+) component.

Maximum trip out time: < 30 ms after break through.

Timer: adjustable 1 s - 9 min 59 s with resolution of 1 s. Timer OFF function available.

3.2. Burn out (HV position)

Selectable voltage 100 V ÷ 5000 V
 Minimum burn out time before overheating: 10 s
 I max.: 50 mA ÷ 60 mA

3.3. Low resistance (Continuity position)

Resistance readout for currents 10 A and 25 A

Measuring range according to EN 61557-4 is 0.011 Ω to 2.000 Ω

Range R (Ω) [*]	Resolution (Ω)	Accuracy
0.000 ÷ 0.999	0.001	±(3 % of reading + 3 dig.)
1.000 ÷ 2.000	0.001	±(3 % of reading + 10 dig.)
2.001 ÷ 9.999	0.001	indicator only

* autoranging

Resistance readout for current 0.10 A

Range R (Ω) [*]	Resolution (Ω)	Accuracy
0.0 ÷ 9.9	0.1	±(5 % of reading + 12 dig.)
10.0 ÷ 99.9	0.1	±(5 % of reading + 6 dig.)
100.0 ÷ 999.9	0.1	±10 % of reading

* autoranging

Resistance readout for current 0.20 A

Measuring range according to EN 61557-4 is 0.24 Ω to 100.0 Ω

Range R (Ω) [*]	Resolution (Ω)	Accuracy
0.00 ÷ 99.9	0.1	±(5 % of reading + 6 dig.)
100.0 ÷ 999.9	0.1	±10 % of reading

* autoranging

Max. output voltage: <6 V~

Measuring current (electronically stabilized) selectable 100 mA, 200 mA, 10 A, 25 A

- 100 mA at R < 50 Ω (U_{mains} : 115 V / 230 V, original test leads)
- 200 mA at R < 8 Ω (U_{mains} : 115 V / 230 V, original test leads)
- 10 A.....at R < 0.5 Ω (U_{mains} : 115 V / 230 V, original test leads)
- 25 A.....at R < 0.2 Ω (U_{mains} : 115 V / 230 V, original test leads)

Current shape: sinusoidal

Limit value adjustable: 10 m Ω ÷ 1.0 Ω (in steps of 10 m Ω),
 1.0 Ω ÷ 2.0 Ω (in steps of 100 m Ω),
 or ignored (** Ω sign is selected)

Timer: adjustable 1 s ÷ 59 s, resolution 1 s

Connection system: 4 wire, safety connectors, electrically separated

Test voltage readout with currents 10 A and 25 A

Range (V)	Resolution (V)	Accuracy
0.000 – 10.000	0.001	±(3 % of reading + 0.05 V)

Test voltage readout with currents 0.1 A and 0.2 A

Range (V)	Resolution (V)	Accuracy
0.000 – 10.000	0.001	±(5 % of reading + 0.1 V)

Test current readout 10 A and 25 A

Range (A)	Resolution (A)	Accuracy
0.0 – 30.0	0.1	±(3 % of reading + 5 dig.)

Test current readout 0.1A and 0.2A

Range (A)	Resolution (A)	Accuracy
0.000 – 1.000	0.001	±(5 % of reading + 5 dig.)

3.4. Voltage drop scaled to 10 A~ (option in Continuity position)**Voltage drop readout (scaled to 10A~)**

Range ΔU (V)	Resolution (V)	Accuracy
0.00 – 10.00	0.01	±(3 % of reading + 3 dig.)
10.00 – 99.99	0.01	indicator only

Test current readout

Range (A)	Resolution (A)	Accuracy
0.0 – 30.0	0.1	±(3 % of reading + 3 dig.)

Limit value of voltage drop versus wire section:

Wire section (mm ²)	Limit voltage drop (V)
0.5	5.0
0.75	5.0
1	3.3
1.5	2.6
2.5	1.9
4	1.4
≥6	1.0

Any of the wire sections in the previous table can be selected in order to evaluate voltage drop result.

Max. output voltage: 10 V~
 Electronically stabilized current
 Current shape: sinusoidal
 Measuring current (external resistance of 0.0 Ω - 0.5 Ω connected to original test cable): >10 A~
 Timer: adjustable 1 s - 59 s, resolution 1 s
 Connection system: 4 wire, safety connectors, electrically separated

3.5. Insulation resistance

• Nominal voltage 250 V, 500 V, 1000 V \equiv

Insulation resistance readout:

Measuring range according to EN 61557-2 is 0.04 M Ω to 999 M Ω

Range* (M Ω)	Resolution ** (M Ω)	Accuracy
0.000 - 1.999	0.001	$\pm(5\%$ of reading + 10 dig.)
2.000 - 199.9	0.001, 0.01, 0.1	$\pm(3\%$ of reading + 3 dig.)
200 - 999	1	$\pm(10\%$ of reading + 10 dig.)

* autoranging, depends on test voltage

** depends on test voltage

Measuring range (stable and accurate result even with capacitive load):0 M Ω - 1 M Ω

Nominal voltage: 250 V, 500 V, 1000 V \equiv (+30 % / - 0 %)

Short circuit current: 3.5 mA max.

Measuring current: 1 mA min. at 250 k Ω / 250 V, 500 k Ω / 500 V, 1000 k Ω / 1000 V

Settable limits: 0.2 M Ω - 200.0 M Ω (resolution 0.1 M Ω), no limit
 (** M Ω sign is selected)

Timer: adjustable 1 s - 9 min 59 s with resolution of 1 s
 Timer OFF function available.

Subresult: measuring voltage

Output: 2 safety plugs, grounded

Auto-discharge after test.

3.6. PE leakage current

Leakage current readout:

Range (mA)	Resolution (mA)	Accuracy
0.00 - 3.99	0.01	$\pm(5\%$ of reading + 3 dig.)
4.0 - 20.0	0.1	$\pm(5\%$ of reading + 3 dig.)

Settable limits: 0.1 mA - 20.0 mA (in step of 0.1 mA)

Output: 16 A power test socket

Timer: adjustable 1 s - 9 min 59 s with resolution 1 s

Timer OFF function available.

Frequency response:complies to EN61010-Figure A1

3.7. Substitute leakage current

Substitute leakage current readout:

Range (mA)	Resolution (mA)	Accuracy
0.00 – 20.0	0.01	±(5 % of reading + 3 dig.)

Settable limits: 0.1 mA – 20.0 mA (in step of 0.1 mA)

Short circuit current:..... < 30 mA

Open circuit voltage: 40 V

Output: 16 A power test socket

Displayed current is calculated to 115 V / 230 V.

Frequency response.....complies to EN61010-Figure A1

3.8. Touch leakage current

Touch leakage current readout:

Range (mA)	Resolution (mA)	Accuracy
0.00 – 2.00	0.01	±(5 % of reading + 3 dig.)

Settable limits: 0.1 mA – 2.0 mA (in step of 0.1 mA)

Output: 16 A power test socket + TOUCH safety plug

R_{Ameter} : 2 k Ω

Frequency response.....complies to EN61010-Figure A1

3.9. Functional test

Active Power, Apparent Power, Voltage, Current and Frequency monitoring on the test socket:

Active Power, Apparent Power

Range (W)	Resolution (W)	Accuracy
0 – 199.9	0.1	$\pm(5\% \text{ of reading} + 10 \text{ digit})$
200 – 3500	1	$\pm(5\% \text{ of reading} + 3 \text{ digit})$

Test voltage readout

Range (V)	Resolution (V)	Accuracy
0 – 400 V	1	$\pm(2\% \text{ of reading} + 2 \text{ digit})$

Test current readout

Range (A)	Resolution (A)	Accuracy
0 – 0.999	0.001	$\pm(3\% \text{ of reading} + 5 \text{ dig.})$
1.00 – 15.99	0.01	$\pm(5\% \text{ of reading} + 5 \text{ dig.})$

Cos ϕ readout

Range	Resolution	Accuracy
0 – 1.00	0.01	$\pm(3\% \text{ of reading} + 3 \text{ dig.})$

Frequency readout

Range (Hz)	Resolution (Hz)	Accuracy
45.00 – 65.00	0.01	$\pm(0.1\% \text{ of reading} + 3 \text{ dig.})$

Limit Apparent Power:adjustable 10 VA ÷ 3500 VA
 10 VA ÷ 100 VA (resolution 1 VA)
 100 VA ÷ 3500 VA (resolution 10 VA)

Output: 16 A power test socket

Timer:adjustable 1 s - 9 min 59 s with resolution 1 s

Timer OFF function available.

3.10. Discharge time (DISC.TIME position)

• Discharge time on power plug (external)

Max. working voltage	750V p
Min. working voltage	70 Vp, 140 V p
Measuring range	0 s - 10 s
Resolution	0.1 s
Limit of discharging time	1 s
Accuracy	±(2 % of reading + 0.2 s)
Safe voltage level	60 V, 120 V
Internal resistance of input.....	96 MΩ

• Discharge time on internal electronic components (internal)

Max. working voltage	750 V p
Min. working voltage	70 Vp, 140 V p
Measuring range	0 s - 10 s
Resolution	0.1 s
Limit of discharging time	5 s
Accuracy	±(2% of reading + 0.2 s)
Safe voltage level	60 V, 120 V
Internal resistance of input.....	96 MΩ

3.11. General

Mains voltage:.....	230 V (-10 % ÷ +6 %) / 50 Hz, 60 Hz
Mains voltage1:.....	115 V (-10 % ÷ +6 %) / 50 Hz, 60 Hz
Max. power consumption:	720 VA (without load on TEST SOCKET) @ 230 V
Max. power consumption:	3.85 kVA (with load on TEST SOCKET) @ 230 V
Max. power consumption:	660 VA (without load on TEST SOCKET) @ 115 V
Max. power consumption:	1.9 kVA (with load on TEST SOCKET) @ 115 V
Mains supply overvoltage category.....	Cat II / 300V

Display:.....	LCD dot matrix, (160 x 116) dots with cont. backlight
Communication interface	USB/RS232
Interface selection:.....	keyboard
RS232 interface:	1 start bit, 8 data bits, 1 stop bit
RS232 baud rate adjustable:	9600, 19200, 38400 Baud
USB baud rate:	9600, 19200, 38400 Baud
Memory:.....	1638 memory locations
Remote control signals:	START / STOP, SAVE
EXT/ Door in signals:	Next test, Pass / Fail result, External input, Door in
Bar code reader:	EAN13
Bar code baud rate adjustable: .	2400, 4800 or 9600 Baud

Measurement circuitry protection:

F1 F 5 A / 250 V (5 mm × 20 mm) (general protection of the instrument)

F2 F 5 A / 250 V (5 mm × 20 mm) (general protection of the instrument)

F3 T 16 A / 250 V (6.3 mm × 32 mm) (test socket protection)

F4 T 16 A / 250 V (6.3 mm × 32 mm) (test socket protection)

Case: shock proof plastic / portable

Dimensions (w × h × d): 410 mm × 175 mm × 370 mm

Weight (without accessories): 13.5 kg

Pollution degree: 2

Degree of protection (at closed cover): IP 50

Overtoltage category: Cat III / 300V, Cat II / 600V

Protection classification: I

Working temp. range: 0 °C ÷ +40 °C

Ref. temp. range: +10 °C ÷ +30 °C

Ref. humidity range: +40 RH ÷ +70 % RH

Storage temp. range: -10 °C ÷ +60 °C

Max. working humidity: 85% RH (0 °C ÷ +40 °C)

Max. storage humidity: 90% RH (-10 °C ÷ +40 °C)

80% RH (+40 °C ÷ +60 °C)

Accuracies apply for 1 year in reference conditions. Temperature coefficient outside this limits is 0.1% of measured value per °C and 1 digit.

Withstanding proof test:

- Between mains and withstanding terminals 7500 Veff / 1 min
- Between mains and accessible metallic parts
(internal voltage limiting device) 300 Veff / 1 min
- Between mains and other terminals 2200 Veff / 1 min.

4. Measurements

4.1. Withstanding test:

Warning !

- Disconnect all unused test leads before starting measurement; otherwise the instrument can be damaged!
- Only a skilled person, who is familiar with hazardous voltage operations, can perform this measurement!
- Check instrument and test leads for any sign of damage or abnormality before connecting them to the instrument. DO NOT use test probes in case of any damage or abnormality!
- Always handle the instrument and connected accessories as the Withstanding test sockets and leads are under the hazardous voltage!
- Never touch exposed probe tip, connected equipment under test, or any other energized part during the measurements. Make sure that NOBODY else can contact them either!
- Connect test probes only for withstanding measurement, and disconnect them immediately after the test!
- DO NOT touch any part of test probe in front of the barrier (keep your fingers behind the finger guards of the probe) – possible danger of electric shock!

Always set the lowest possible trip-out current.

HV (high voltage) position

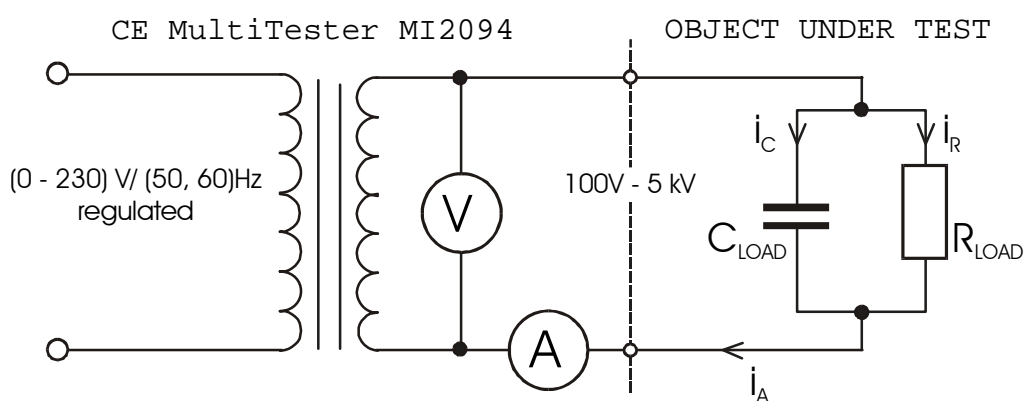

Fig. 2. Test circuitry

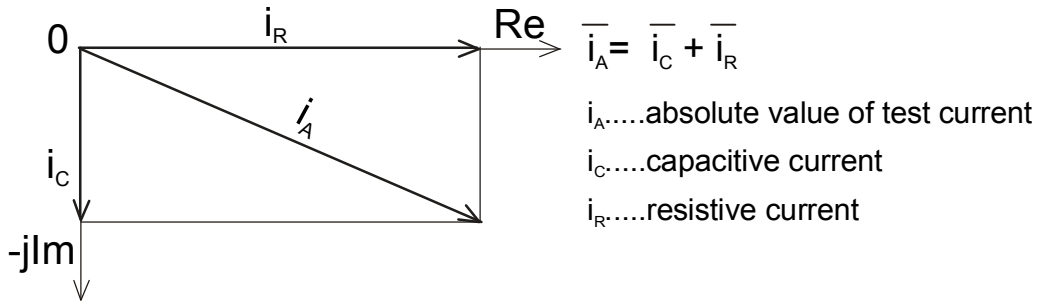

Fig. 3. Test current diagram

How to carry out the measurement

STEP 1. Set rotary switch to HV (high voltage) position. The following heading is displayed:

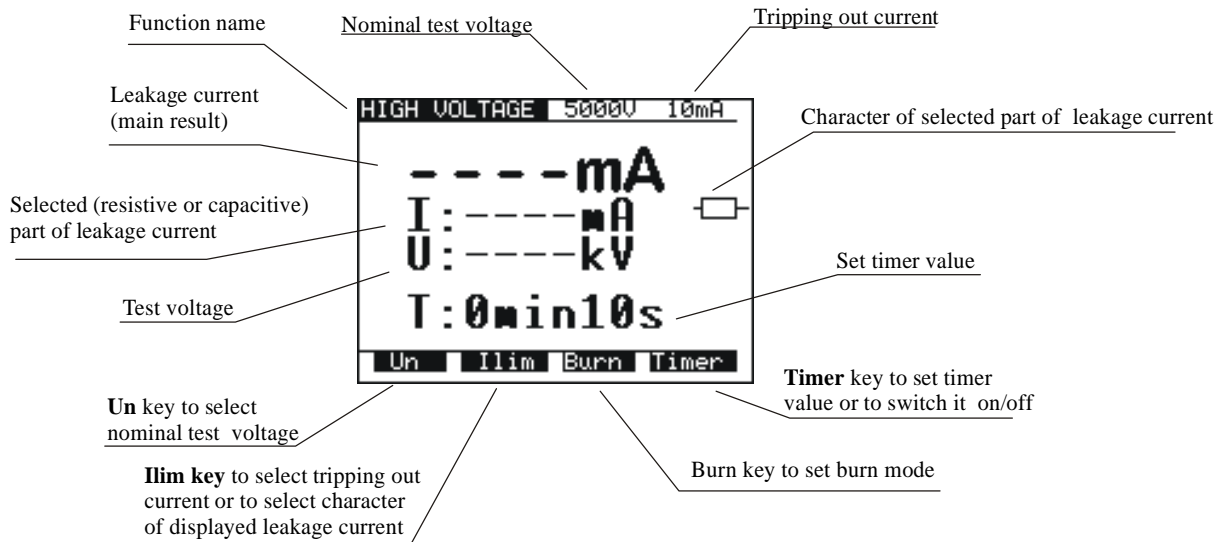

Fig. 4. Main menu in HV function

STEP 2. Select test parameters as follows:

- Test voltage
 - Use **U_N** key to select appropriate test voltage that can be set using $\uparrow \downarrow$ keys from 100 V to 1000 V in 10 V steps and from 1000 V to 5000 V in 50 V steps.

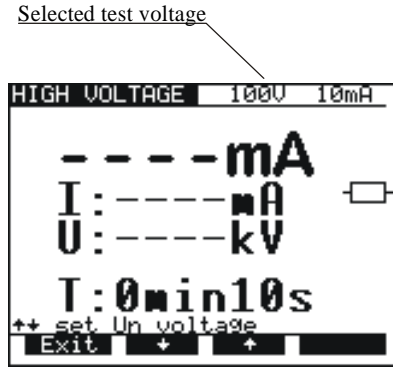

Fig. 5. Test voltage selection menu

- Press **Exit** key to exit Test voltage selection menu.
- **Trip-out current / character of displayed part of leakage current**
 - Press **Ilim** key in order to reach menu for trip-out current selection and character of displayed part of leakage current (resistive or capacitive). See the following figure.

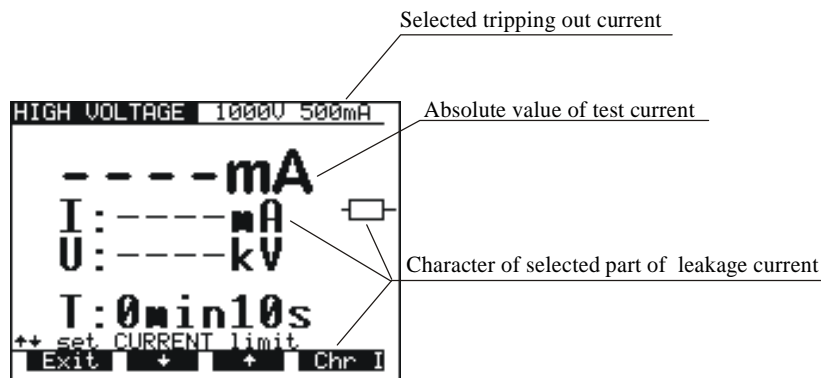

Fig. 6. Trip-out current selection menu

- Use \uparrow and \downarrow keys to select appropriate trip-out current.
- Press **Chr I** in order to change the character of displayed part of leakage current. If the selected part is resistive, \square sign is displayed behind mA unit. For capacitive part $\text{—}|$ sign is displayed behind mA unit.
- Press **Exit** key to exit Trip-out current selection menu.

Notes!

The set Limit value of test current is always compared with the absolute value of test current.

It is possible to set the limit for minimum test current to inform the user for the possibility that test probes are not connected to tested insulation. See 5.5. *System configuration*.

- **Timer value / timer OFF/ON**

- Press **Timer** key and the menu for timer value selection is displayed.
- Use \uparrow and \downarrow keys to select appropriate test time value.
- To deactivate the timer press **Toff** key or **Ton** key to activate it. See the following figure.

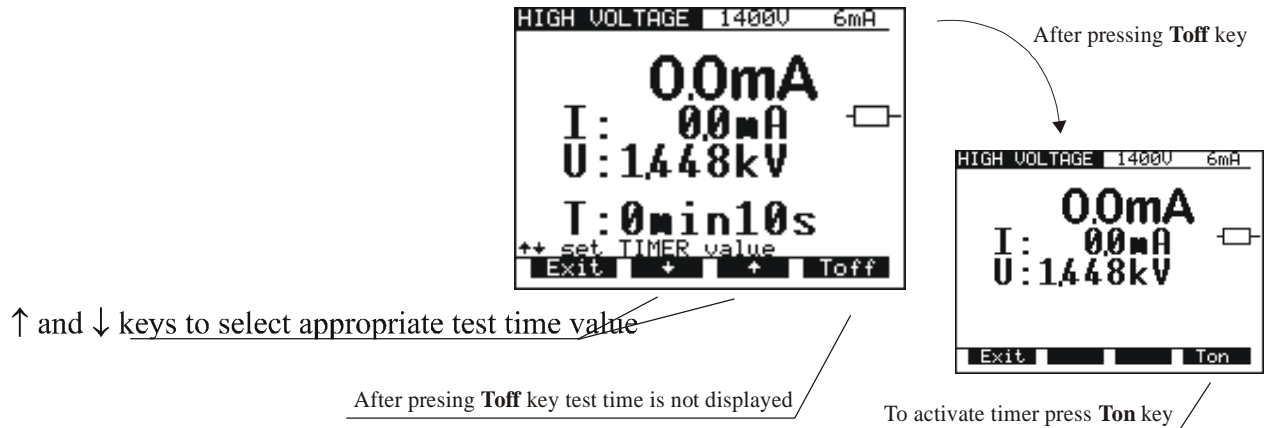

Fig. 7. Timer value selection menu

- Press **Exit** key to exit Timer value selection menu.

- **BURN mode**

- Press **Burn** key to select Burn mode. In this mode current is limited only by the internal generator characteristics.

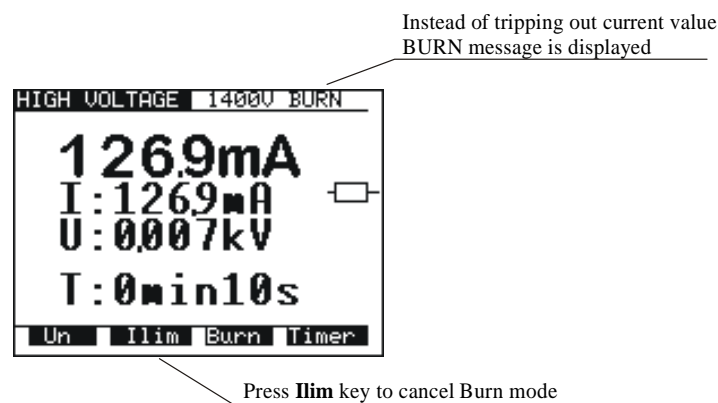

Fig. 8. Main menu in HV function when the BURN mode is selected

Note!

The result of BURN test cannot be saved

STEP 3. Connect test probes to the instrument as shown in figure below.

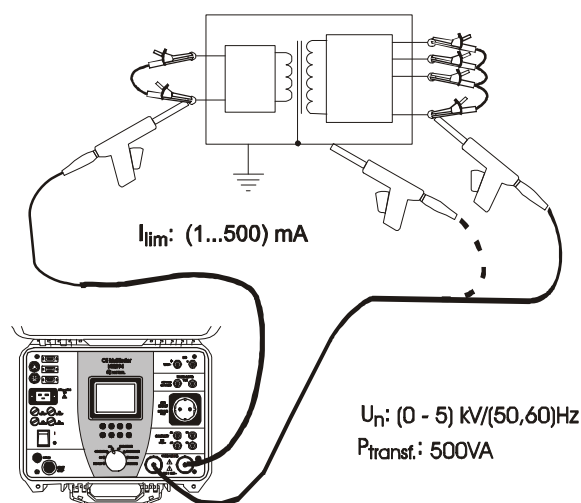

Fig. 9. Connection of test probes

STEP 4. Close **DOOR IN** safety connector if enabled. (CONTINUITY test terminals have to be open).

STEP 5. Press **START/STOP** key to start high voltage generator and carry out the test using test probes.

STEP 6. Wait for the test time to elapse (if the timer has been switched on) or press **START/STOP** key again to stop high voltage generator.

STEP 7. Save displayed result for documentation purposes (see instruction in chapter 5.2. on how to save displayed result).

Notes!

- Take care when using HV test probes - hazardous voltage!
- Use timer ON mode or optional REMOTE CONTROL pedal to stop the measurement when test probes are still connected to equipment under test. The displayed result obtained in this way can be stored to memory for documentation purposes (except in BURN test).
- It is advisable to connect test pistols to the equipment under test before pressing START/STOP pedal to avoid sparking and trip out of the HV generator.
- It is advisable to use the optional WARNING LAMP connected to the instrument, especially if the measurements are to be done away from the instrument using optional test probes with longer cables.
- If there is a test current higher than the preset limit, HV generator trips automatically after reaching that value. Preset limit value is displayed as a result in this instance.

4.2. Withstanding test with preset voltage/time diagram:

WARNING !

- **Disconnect all unused test leads before starting measurement, otherwise the instrument can be damaged!**
- **Only a skilled person, who is familiar with hazardous voltage operations, can perform this measurement!**
- **Check instrument and test leads for any sign of damage or abnormality before connecting them to the instrument. DO NOT use test probes in case of any damage or abnormality!**
- **Always handle the instrument and connected accessories as the Withstanding test sockets and leads are under the hazardous voltage!**
- **Never touch exposed probe tip, connected equipment under test or any other energized part during the measurements. Make sure that NOBODY can contact them either!**
- **Connect test probes only for withstanding measurement, and disconnect them immediately after the test!**
- **DO NOT touch any part of test probe in front of the barrier (keep your fingers behind the finger guards of the probe) – possible danger of electric shock!**

Always set the lowest possible trip-out current.

PROG.HV (programmed HV) position

How to carry out the measurement

STEP 1. Set rotary switch to **PROG.HV** (high voltage) position, the following heading is displayed:

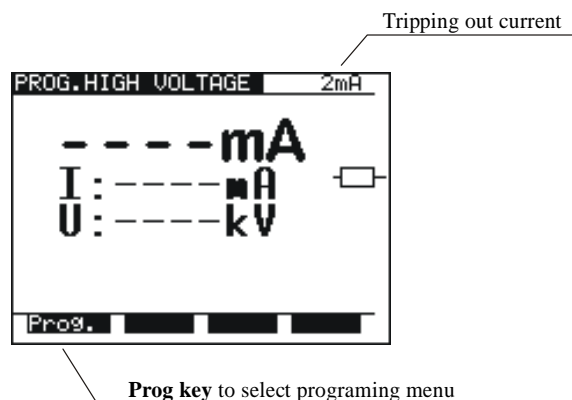

Fig. 10. Main menu in PROG.HV function

STEP 2. Press **Prog.** key to set or to check programmed ramp values in order to prevent damage to the equipment under test (last values used are memorized). Select test parameters as follows:

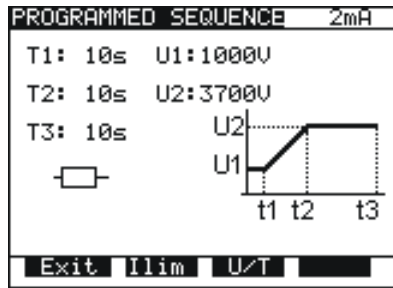

Fig. 11. Menu for programming ramp values

- Press **Ilim** key in order to reach menu for trip-out current selection and character of displayed part of leakage current (resistive or capacitive). The same procedure as for Ilim selection at HV function applies.

Note!

It is possible to set the limit for minimum test current to inform the user for the possibility that test probes are not connected to tested insulation. See 5.5. **System configuration.**

- To change U and T values press **U/T** key. Value **T2** represent time from **t1** to **t2** and value **T3** represent time from **t2** to **t3** (fig. 12). Menu for selection and changing values is displayed, see the following figure:

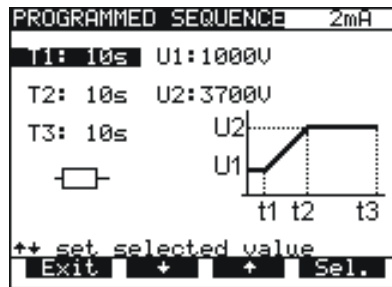

Fig. 12. Timer T1 is selected, change value by using $\uparrow \downarrow$ keys

- To select ramp times or voltage values press **Sel.** key.
- Use \uparrow and \downarrow keys to set appropriate test value:
 - Time: 1 s - 240 s
 - Voltage: 100 V –5 kV
- Press **Exit** key (2x) to exit.

STEP 3. Connect test probes (pistols) to the instrument.

STEP 4. Close **DOOR IN** safety connector if enabled. (CONTINUITY test terminals have to be open).

STEP 5. Press **START/STOP** key to start high voltage generator and carry out the test using test probes.

STEP 6. Wait for the test time to elapse or press **START/STOP** key again to stop high voltage generator.

STEP 7. Save displayed result for documentation purposes (see instruction in chapter 5.2. on how to save displayed result).

4.3. Low resistance test with currents of 0.1A / 0.2A / 10A / 25A~

CONTINUITY position

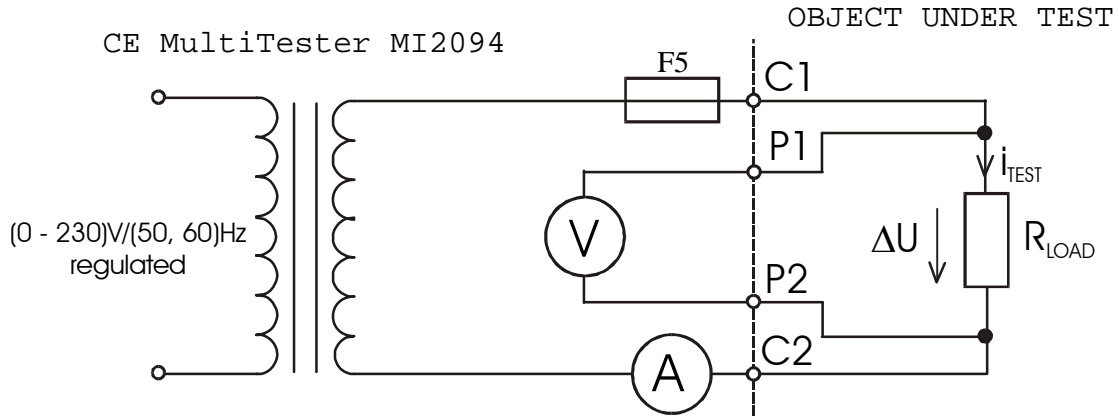

Fig. 13. Test circuitry

How to carry out the measurement

STEP 1. Set rotary switch to **Continuity** position. The following heading is displayed.

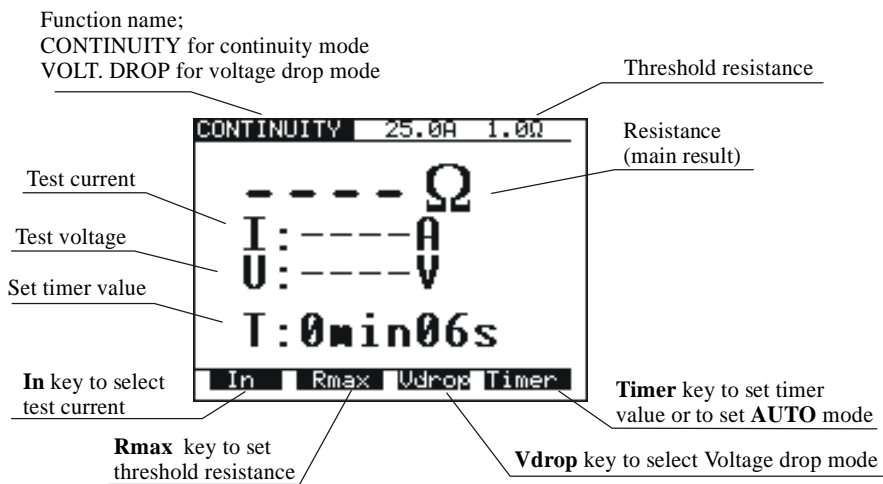

Fig. 14. Main menu in Continuity function

STEP 2. Select test parameters as follows:

- **Measurement current**
 - Use **In** key to select appropriate measurement current.
- **Resistance limit**
 - Press **R_{max}** key in order to reach the menu for selection of resistance limit (see the following figure).

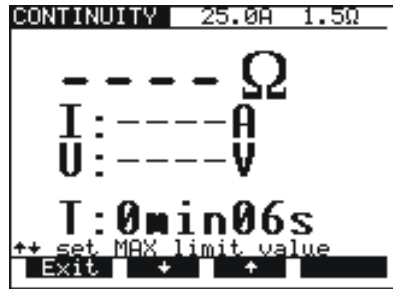

Fig. 15. Low resistance limit selection menu

- Use \uparrow and \downarrow keys to select appropriate limit value. If the displayed result is higher than the set limit, the result will be accompanied by an error sound signal (after completion of the measurement). No limit value will be selected and no sound signal will be activated when " *** Ω " is selected.
- Press **Exit** key to exit **Low resistance limit** selection menu.
- **Timer value + AUTO start option**
 - Press **Timer** key and the menu for selection of timer value is displayed.

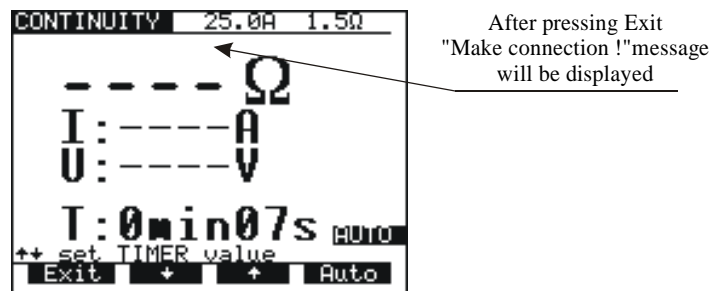

Fig.16. Timer value selection menu with auto option

- Use \uparrow and \downarrow keys to select appropriate test time value.
- To activate the measurement automatically when the instrument is connected to the equipment under test press the **Auto** key. In this mode a small voltage value is always present on the continuity test terminals. The flow of a small current across the tested item when the test terminals are connected will activate the measurement. By turning the ROTARY SWITCH or switching off the instrument the AUTO function is automatically disabled.

STEP 3. Connect test probes to the instrument and to the tested item as shown in the figure below.

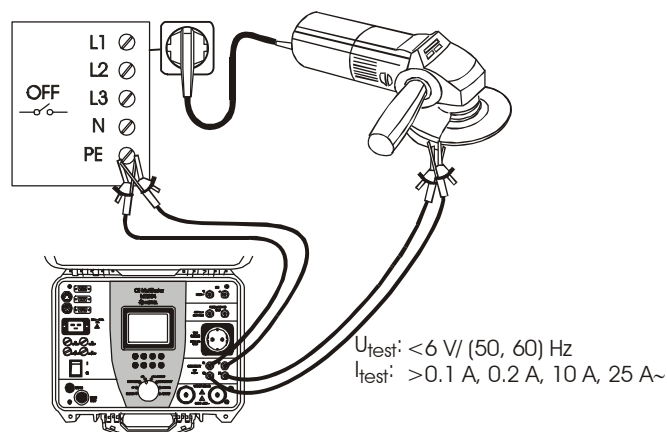

Fig. 17. Connection of test leads

STEP 4. Press **START/STOP** key to start the measurement.

STEP 5. Wait for the set time to elapse or press **START/STOP** key again to stop the measurement.

STEP 6. Save displayed result for documentation purposes (see instruction in chapter 5.2. on how to save displayed result).

Note!

Test results can be adversely affected by impedances of additional operating circuits connected in parallel with the tested device or by transient currents.

4.4. Voltage drop scaled to test current of 10 A~ CONTINUITY position

How to carry out the measurement

STEP 1. Set rotary switch to **CONTINUITY** position, press **Vdrop** key. The following heading is displayed.

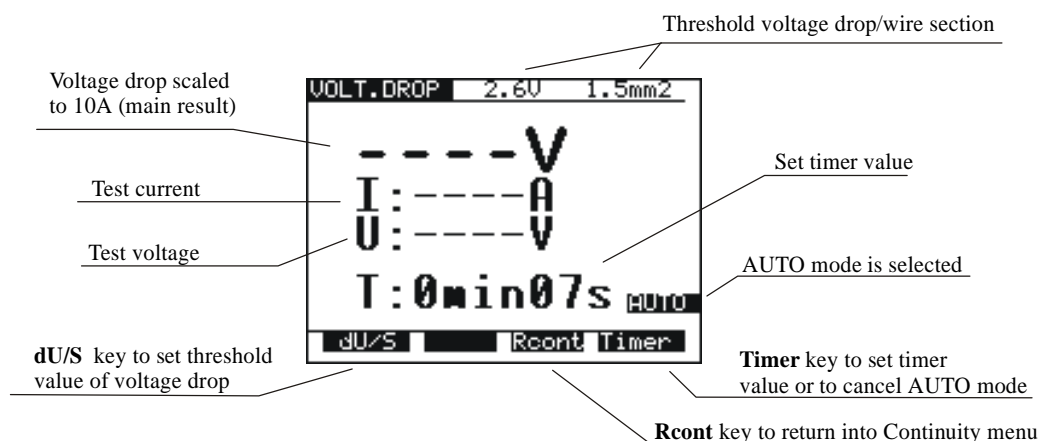

Fig. 18. Main menu in Voltage drop function

STEP 2. Select test parameters as follows:

- **Voltage drop limit.**
 - Use **dU/S** key to select appropriate limit, see the table in paragraph 3.4.
- **Timer value + AUTO start option**
 - See instructions in paragraph 4.3.

STEP 3. Connect test probes to the instrument and to equipment under test as shown in the following figure:

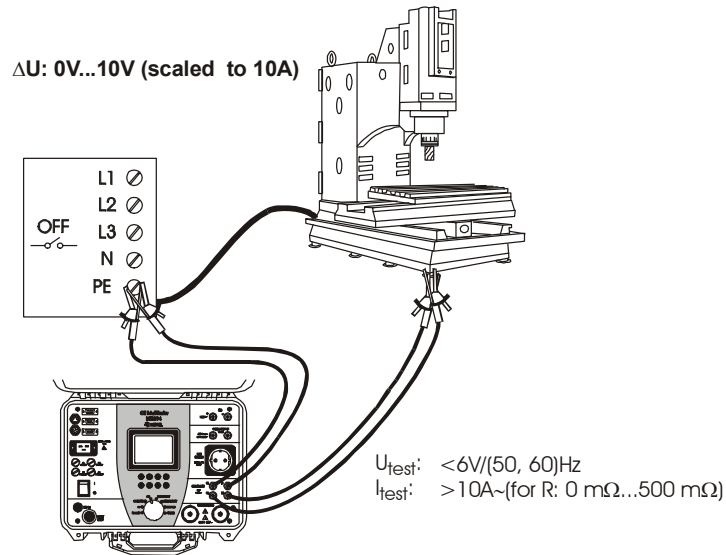

Fig. 19. Connection of test leads

STEP 4. Press **START/STOP** key to start the measurement.

STEP 5. Wait for the set time to elapse or press **START/STOP** key again to stop the measurement.

STEP 6. Save displayed result for documentation purpose (see instruction in chapter 5.2. on how to save displayed result).

Note!

Test results can be adversely affected by impedances of additional operating circuits connected in parallel with the tested device or by transient currents.

4.5. Insulation resistance

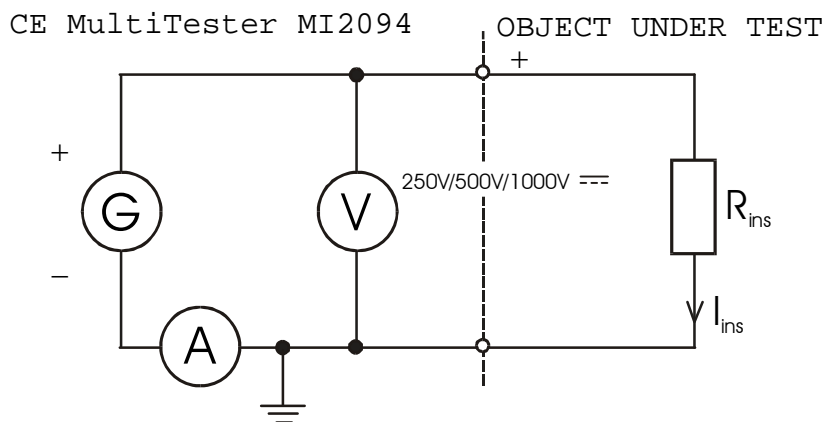

Fig. 20. Test circuitry

How to carry out the measurement

STEP 1. Set rotary switch to **ISO** (insulation resistance) position, the following heading is displayed.

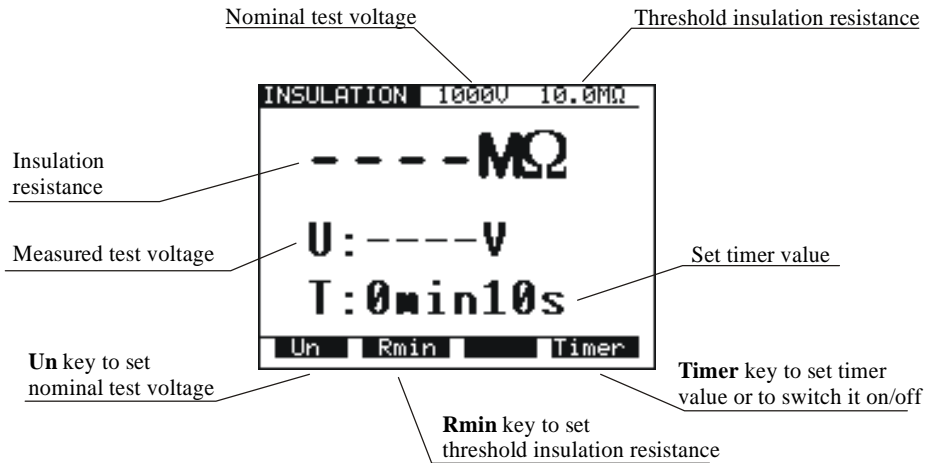

Fig. 21. Basic heading in ISO function

STEP 2. Select test parameters as follows:

- **Insulation resistance limit**

- Press **Rmin** key in order to reach menu for selection of insulation resistance limit, see the following figure.

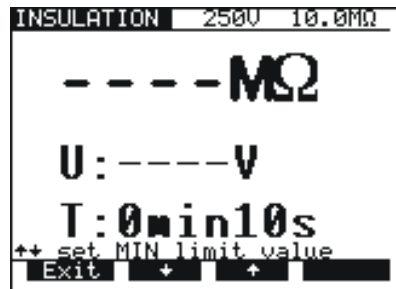

Fig. 22. Insulation resistance limit selection menu

- Use \uparrow and \downarrow keys to select appropriate limit value. If the displayed result is lower than the set limit value, it will be accompanied by an error sound signal (after completion of the measurement). There will be no limit value selected and no sound signal will be activated if "**** MΩ" sign is selected.
- Press **Exit** key to exit Insulation resistance limit selection menu.

- **Test voltage**
 - Use **Un** key to select appropriate test voltage (250 V \approx , 500 V \approx , or 1000 V \approx).
- **Timer value**
 - See instructions on how to set the value in paragraph 4.1. STEP 2.
- **Timer ON/OFF**
 - See instruction in paragraph 4.1. STEP 2.

STEP 3. Connect test probes to the instrument and to the equipment under test as shown in figure below:

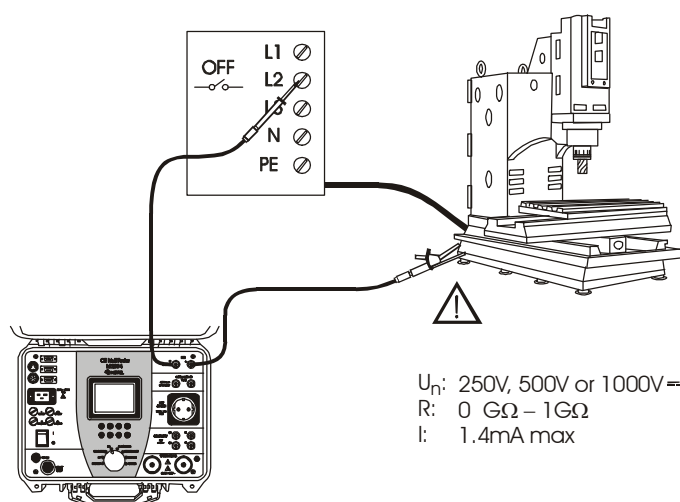

Fig. 23. Connection of test leads

- STEP 4.** Press **START/STOP** key to start the measurement.
- STEP 5.** Wait for test time to elapse (if the timer has been switched on) or press **START/STOP** key again to stop the measurement.
- STEP 6.** Save displayed result for documentation purposes (see instruction in chapter 5.2. on how to save displayed result).

Notes!

Do not disconnect measured object before it is discharged (resistance result is displayed).

Black banana socket (minus pole of insulation resistance part) is internally connected to ground of CE Multitester and through it to PE mains supply.

4.6. Discharge time - external (input MAINS TEST)

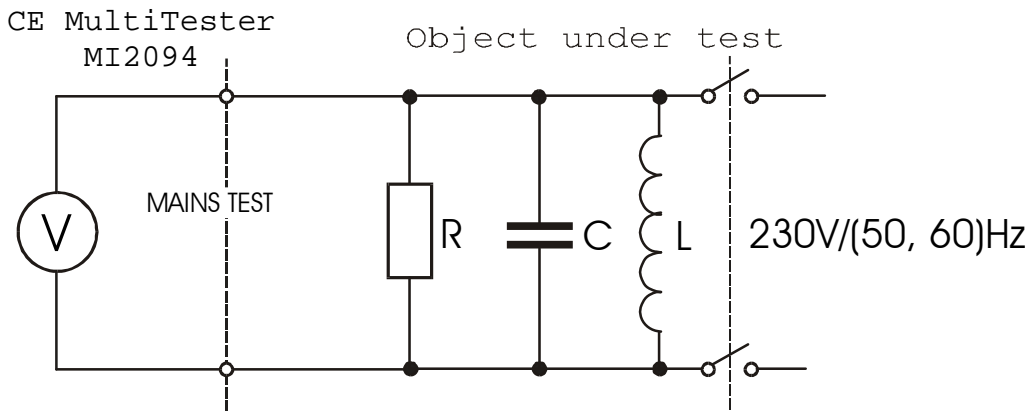

Fig. 24. Test circuitry

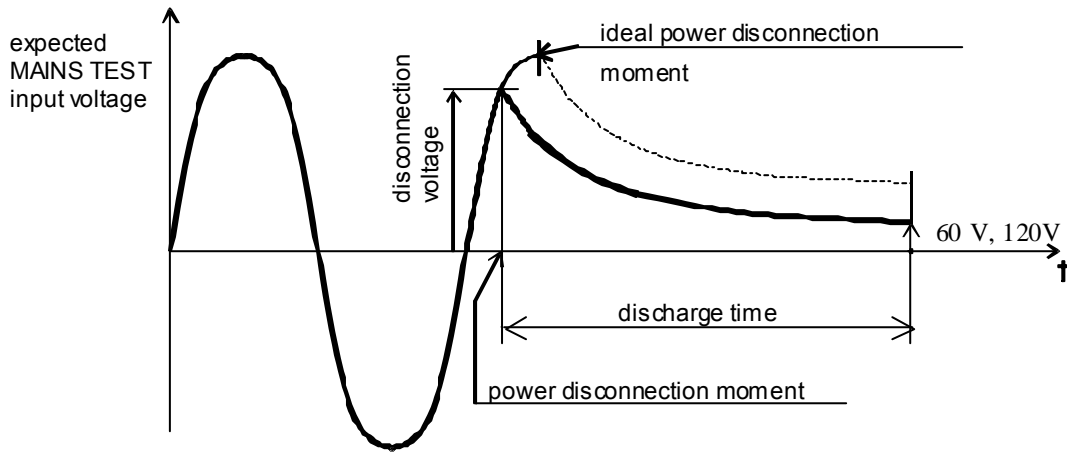

Fig. 25. Voltage on MAINS TEST input

External discharge time is calculated as the input voltage is maximum allowed voltage of the currently connected mains supply system. The instrument is constructed to measure external discharge time in three different mains supply systems (115 V, 230 V and 400 V). The voltage is calculated according to the following nominal voltage peak values:

$179 \text{ Vp} = (115 \text{ V} + 10\%) \times \sqrt{2}$	$(60 \text{ V} < \text{Up} < 235 \text{ V})$
$344 \text{ Vp} = (230 \text{ V} + 6\%) \times \sqrt{2}$	$(235 \text{ V} < \text{Up} < 425 \text{ V})$
$596 \text{ Vp} = (400 \text{ V} + 6\%) \times \sqrt{2}$	$(425 \text{ V} < \text{Up} < 600 \text{ V})$

How to carry out the measurement

STEP 1. Set rotary switch to **DISC.TIME** (discharge time) position. The following heading is displayed.

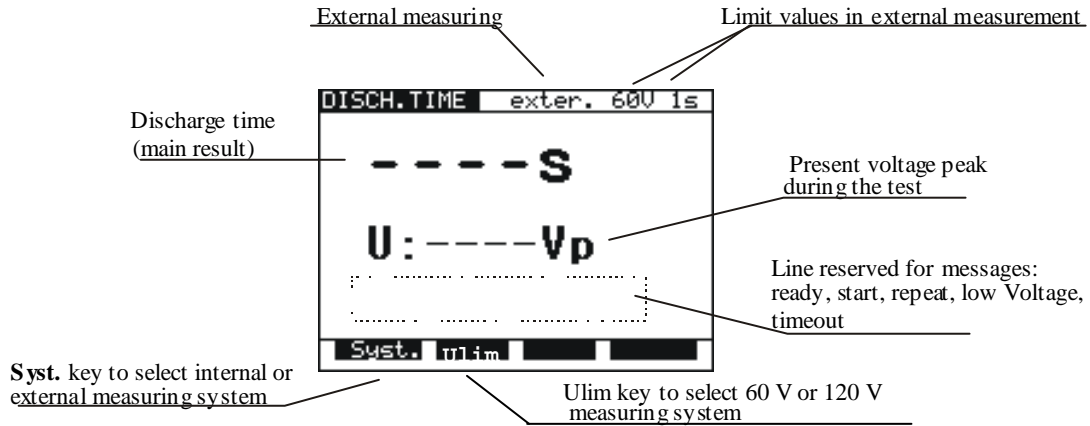

Fig. 26. Main menu in Discharge time function

STEP 2. Select external system measurement by pressing **Syst.** key (**exter. 60 V 1 s** or **exter. 120 V 1 s** is displayed).

STEP 3. Select 60 V or 120 V measuring system using **Ulim** key.

STEP 4. Connect test cable to the instrument and to the equipment under test as shown in figure below.

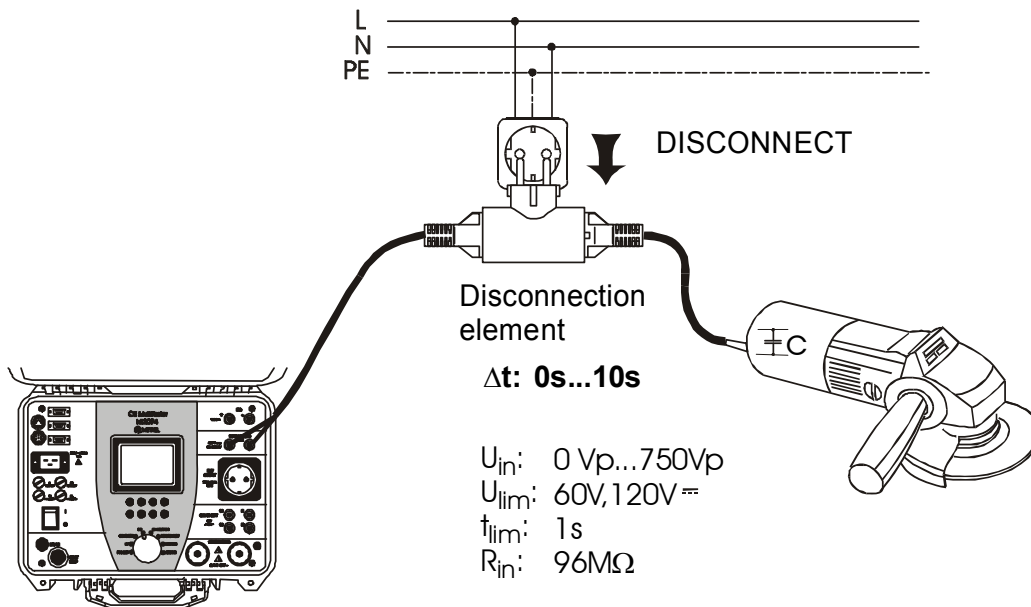

Fig. 27. Connection of test cable

STEP 5. Press **START/STOP** key to prepare the instrument for switching off mains voltage. **Ready** is displayed after approx 1 s. **Low Voltage** message is displayed if the voltage on input mains is not appropriate (less than minimum working voltage) or the input is not connected to the mains (check input circuit, mains voltage, double connection element is not properly plugged in, etc.).

STEP 6. Pull out double connection element and wait for the result to be displayed. If the disconnection voltage is high enough to carry out a measurement, (see fig. 25) **Start** message is displayed and the measurement will be performed. If the voltage is not high enough then the result of 0.0 s and **Repeat** message are displayed. In this instance repeat measurement from STEP 3. If the result 0.0 s and **Repeat** message reappears repeat measurement 5 to 10 times successively. The result 0.0 s can then be accepted as valid. **Timeout** is displayed if the double connection element is not pulled out in 10 s, or discharging time is higher than 10 s.

STEP 7. Save displayed result for documentation purposes (see instructions in chapter 5.2. on how to save displayed result).

4.7. Discharge time-internal

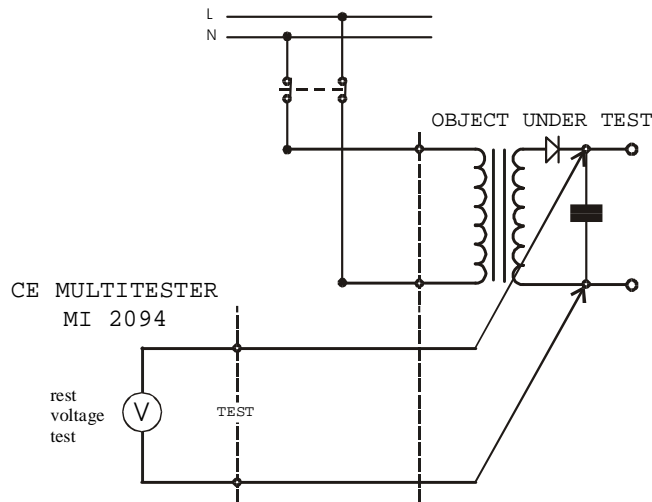

Fig. 28. Test circuitry

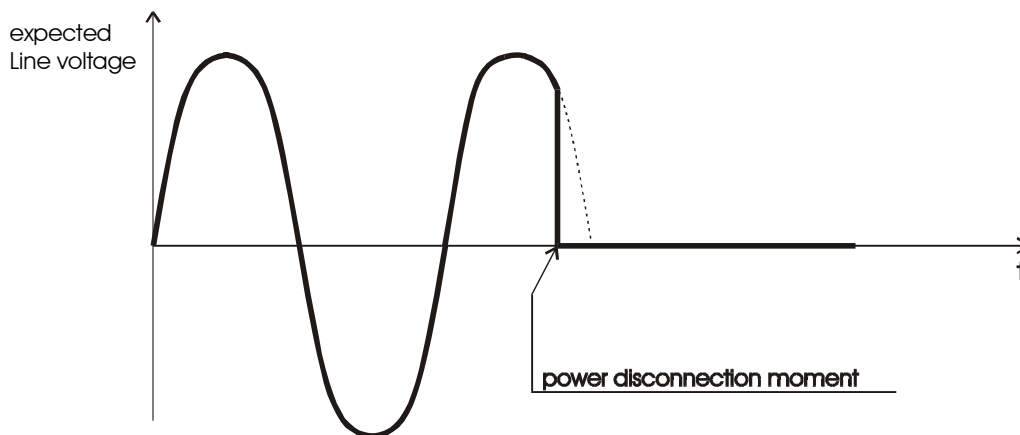

Fig. 29. Expected voltage on tested object input

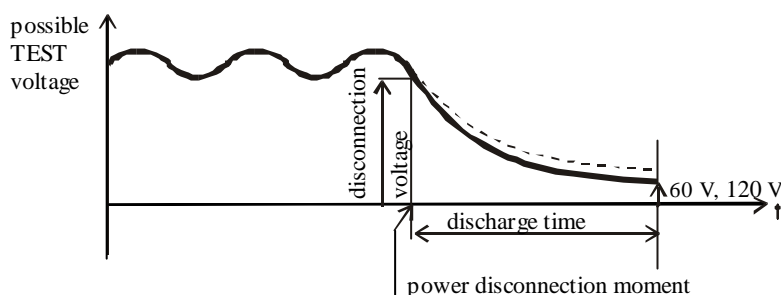

Fig. 30. Expected voltage on discharge input

How to carry out the measurement

- STEP 1.** Set rotary switch to **DISC.TIME** (discharge time) position. The heading according to fig. 26 is displayed.
- STEP 2.** Select internal system measurement by pressing **Syst.** key (**inter. 60 V 5 s** or **inter. 120 V 5 s** is displayed).
- STEP 3.** Select 60 V or 120 V measuring system using **Ulim** key.
- STEP 4.** Connect test cables to equipment under test, and the tested item to line voltage as shown in figure below.

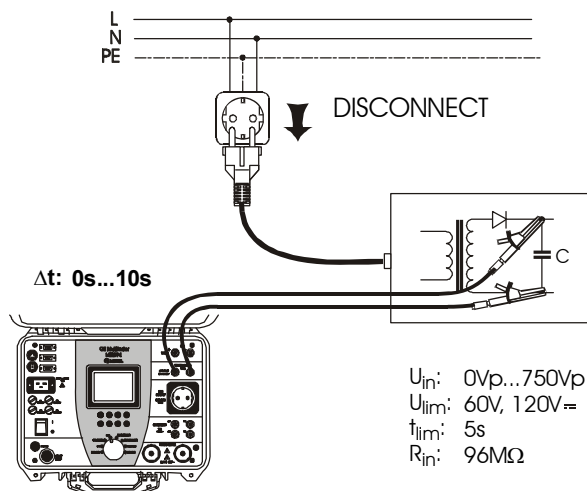

Fig. 31. Connection of test cables

- STEP 5.** Press **START/STOP** key to prepare the instrument for switching off mains voltage. **Ready** is displayed after 1 s approx. **Low Voltage** message is displayed if the voltage on input mains is not appropriate (less than min working voltage) or not connected (check input circuit, mains voltage).
- STEP 6.** Pull out power supply connector and wait for the result to be displayed. If the disconnection voltage is high enough to carry out a measurement (see fig. 25), **Start** message is displayed and the measurement will be performed. If the voltage is not high enough then the result 0.0 s and **Repeat** message are displayed. In this instance repeat measurement from STEP 3. If the result 0.0 s and **Repeat** message reappears repeat measurement 5 to 10 times successively. The result 0.0 s can then be accepted as valid. **Timeout** is displayed if the double connection element is not pulled out in 10 s, or discharging time is higher than 10 s.
- STEP 7.** Save displayed results for documentation purposes (see instruction in chapter 5.2. on how to save displayed results).

4.8. Leakage current

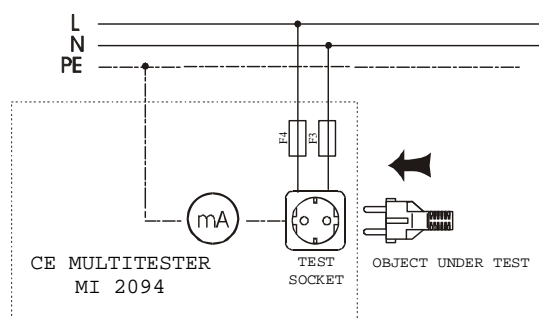

Fig. 32. Test circuitry

How to carry out the measurement

STEP 1. Set rotary switch to **LEAK.CURRENT** position. The following heading is displayed.

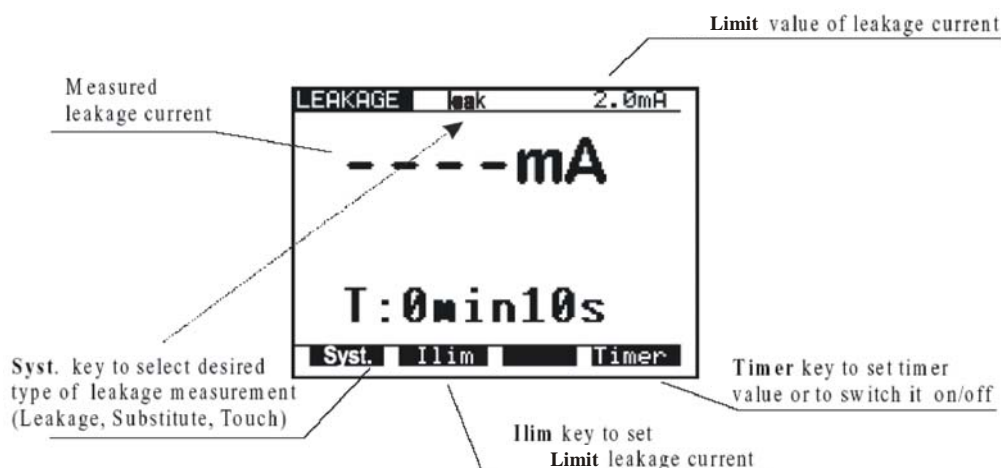

Fig. 33. Main menu in Leakage current function

STEP 2. Select test parameters as follows:

- Press **Syst.** Key to select **leak**
- **Leakage current limit**
 - Press **Ilim** key to open menu to change leakage current limit value.
 - Use **↑** and **↓** keys to select appropriate limit value.
 - Press **Exit** key to exit menu.
- **Timer value**
 - See instructions on how to set the value in paragraph 4.1., STEP 2.
- **Timer ON/OFF**
 - See instructions in paragraph 4.1., STEP 2.

STEP 3. Connect tested item into test socket on the instrument as shown in figure below.

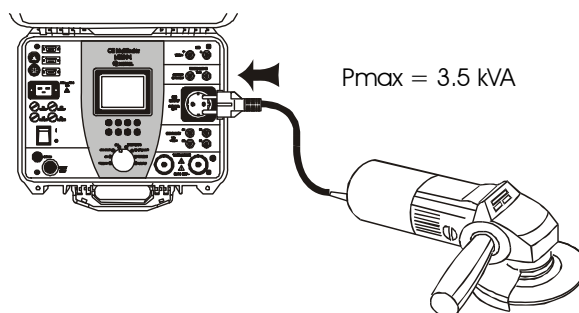

Fig. 34. Connection of tested object

- STEP 4.** Press **START/STOP** key to start the measurement.
- STEP 5.** Wait for the test time to elapse (if the timer has been switched on) or press **START/STOP** key again to stop the measurement.
- STEP 6.** Save displayed result for documentation purpose (see instructions in chapter 5.2. on how to save displayed result).

4.9 Substitute leakage current

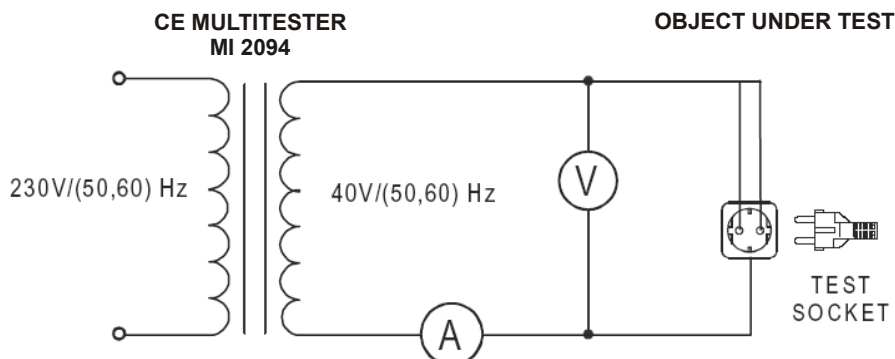

Fig.35. Test circuitry

How to carry out the measurement

STEP 1. Set rotary switch to **LEAK.CURRENT** position.

STEP 2. Select test parameters as follows:

Press **Syst.** key to select **subst**

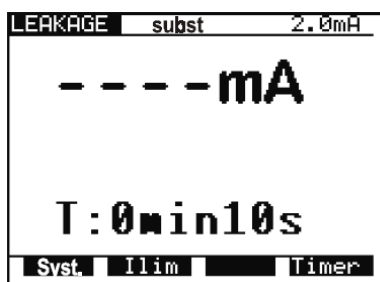

Fig. 36. Heading in Substitute Leakage current function

- Set Leakage current limit
 - Press **Ilim** key to open menu to change leakage current limit value.
 - Use **↑** and **↓** keys to select appropriate limit value.
 - Press **Exit** key to exit menu.
- **Timer value**
 - See instructions on how to set the value in paragraph 4.1., STEP 2.
- **Timer ON/OFF**
 - See instructions in paragraph 4.1., STEP 2.

STEP 3. Connect tested item into test socket on the instrument as shown in figure below.

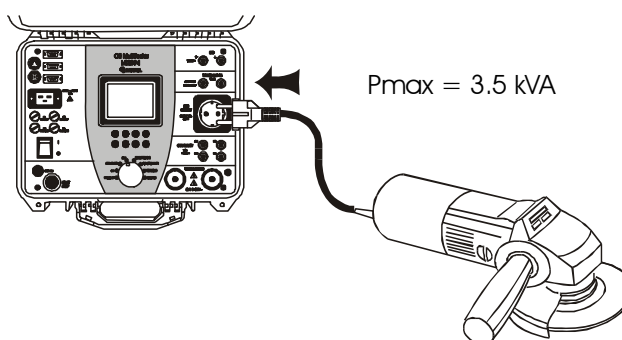

Fig. 37. Connection of tested object

STEP 4. Press **START/STOP** key to start the measurement.

STEP 5. Wait for the test time to elapse (if the timer has been switched on) or press **START/STOP** key again to stop the measurement.

STEP 6. Save displayed result for documentation purpose (see instructions in chapter 5.2. on how to save displayed result).

4.10 Touch leakage current

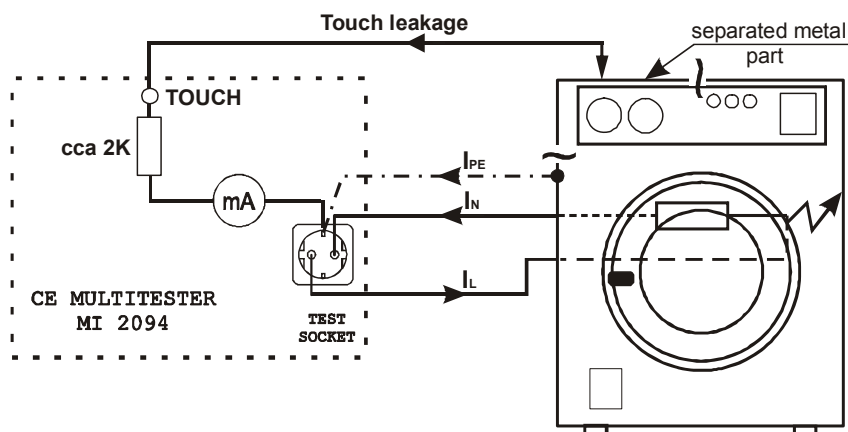

Fig. 38. Touch Leakage test circuitry

How to carry out the measurement

STEP 1. Set rotary switch to **LEAK.CURRENT** position.

STEP 2. Select test parameters as follows:

Press **Syst.** key to select **touch**

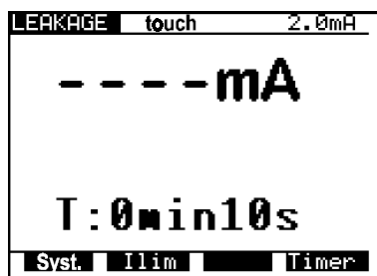

Fig. 39. Heading in Touch Leakage current function

- Set Leakage current limit
 - Press **Ilim** key to open menu to change touch leakage current limit value.
 - Use **↑** and **↓** keys to select appropriate limit value.
 - Press **Exit** key to exit menu.
- **Timer value**
 - See instructions on how to set the value in paragraph 4.1., STEP 2.
- **Timer ON/OFF**
 - See instructions in paragraph 4.1., STEP 2.

STEP 3. Connect tested item into test socket on the instrument as shown in figure below.

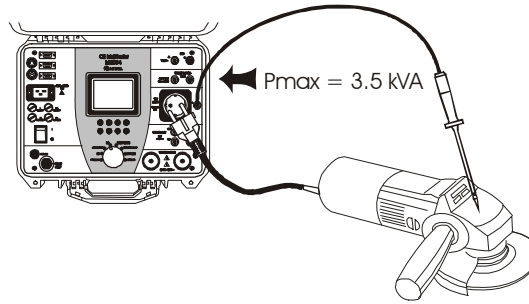

Fig. 40. Connection of tested object

- STEP 4.** Press **START/STOP** key to start the measurement.
- STEP 4.** Touch ungrounded metal part by using test probe.
- STEP 5.** Wait for the test time to elapse (if the timer has been switched on) or press **START/STOP** key again to stop the measurement.
- STEP 6.** Save displayed result for documentation purpose (see instructions in chapter 5.2. on how to save displayed result).

4.11. Functional test

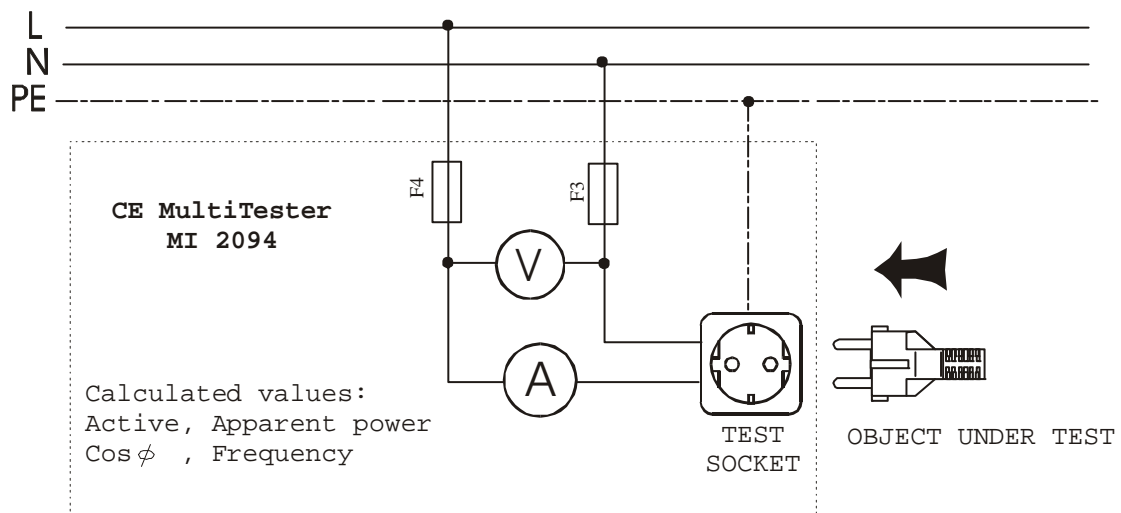

Fig. 41. Test circuitry

How to carry out the measurement

- STEP 1.** Set rotary switch to **FUNCTION. TEST** position, the following heading is displayed.

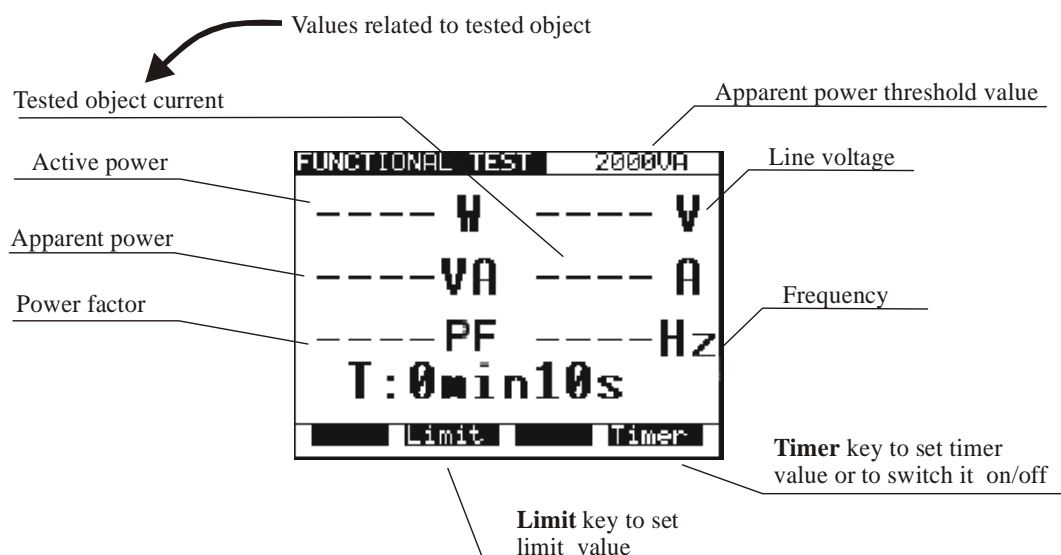

Fig. 42. Main menu in Functional test function

STEP 2. Select test parameters as follows:

- **Apparent power limit value**
 - Press **Limit** key to open menu for changing power limit value.
 - Use **↑** and **↓** keys to select appropriate limit value.
 - Press **Exit** key to exit menu.
- **Timer value**
 - See instructions on how to set the value in paragraph 4.1., STEP 2.
- **Timer ON/OFF**
 - See instructions in paragraph 4.1. STEP 2.

STEP 3. Connect the tested equipment into test socket on the instrument as shown in paragraph 4.8.

STEP 4. Press **START/STOP** key to start the measurement.

STEP 5. Wait for the test time to elapse (if the timer has been switched on) or press **START/STOP** key again to stop the measurement.

STEP 6. Save displayed result for documentation purposes (see instructions in chapter 5.2. on how to save displayed result).

Note!

Dangerous voltage is present on the TEST SOCKET after start of functional test or leakage current measurement. A message " Load on TEST SOCKET " is displayed if the ROTARY SWITCH is in positions PROG. HV, HV, CONTINUITY, ISO, or AUTO, and load is present on TEST SOCKET.

4.12. Autotest

Autotest is a very powerful tool, which is constructed to make the process of measurement easier, more flexible or even automatic. It gives an assurance that the complete measurement procedure is carried out. Any previously designed sequence by CE Link software (up to 10 sequences, each composed of up to 32 steps can be saved in CE MultiTester memory) will be executed step by step. Every measurement result, which has not passed, will be signaled and the automatic procedure will be stopped. When the user removes the cause of the error, he can continue the procedure by pressing START button. In this way the user is sure that every step will be completed with PASS result. The user can decide to skip the failed measurement using SKIP command on the instrument. The result of skipped measurement is not saved into the memory.

When REMOTE CONTROL PEDAL is used and the procedure is stopped at PAUSE or MESSAGE step of sequence, you can continue the procedure only by pressing START button on the instrument.

Rotating the rotary switch during autotest sequence execution is not allowed, otherwise the instrument can block up.

Autotest is a very useful tool for the production line output check of manufactured products, or for laboratory verification that the tested electrical machine meets the appropriate standard. The results of output check can be downloaded (or auto-downloaded, after every tested product) to PC for documentation purpose. Auto-repeat and auto print function after each sequence can be selected in PC software. It is intended to automate the product line checking.

The only way to create autotest sequence is to use Sequence editor in CE Link PC software (32-bit application for Windows) see picture below.

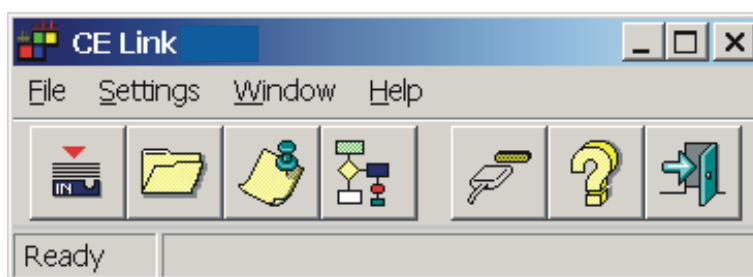

Fig. 43. Main CE Link window

For more information on options in sequence editor see chapter 7, **PC software - CE Link**. When the sequence is completed it must be sent to CE MultiTester by using serial RS232 interface. After sending it, the PC does not need to be connected to the CE MultiTester.

How to carry out the measurement

STEP 1. Install CE Link PC software on your PC.

STEP 2. Using Sequence editor, create the desired sequence. Max. number of steps for each sequence is 32 including programmed pause, messages, barcode reader sequence, sound signals etc.

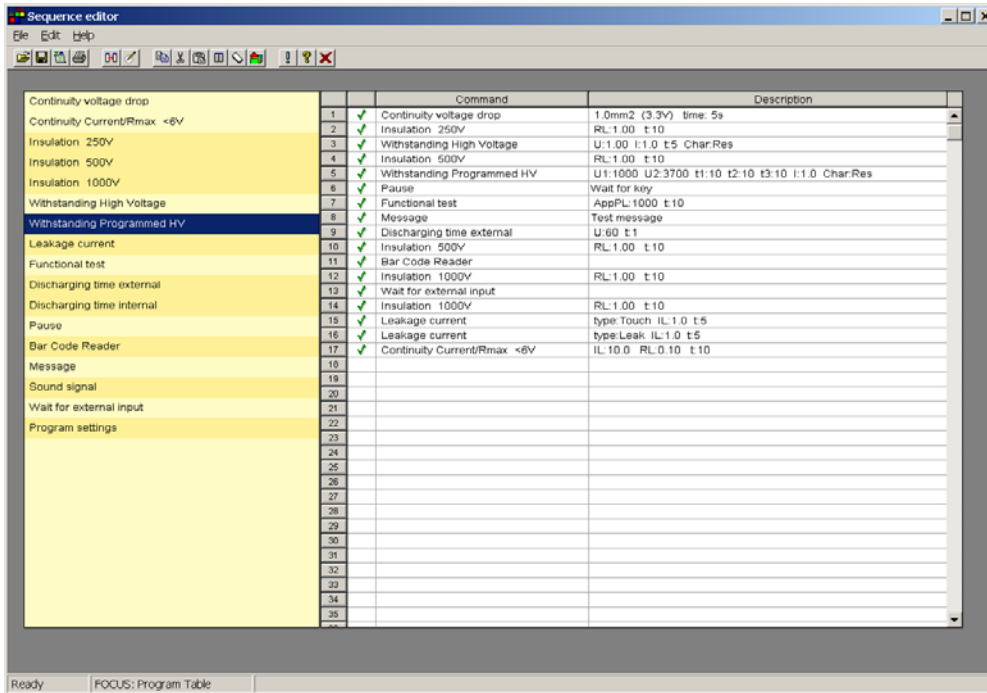

Fig. 44. Sequence editor window

STEP 3. Set rotary switch on the instrument to **AUTOTEST** position, the heading in fig.45 is displayed.

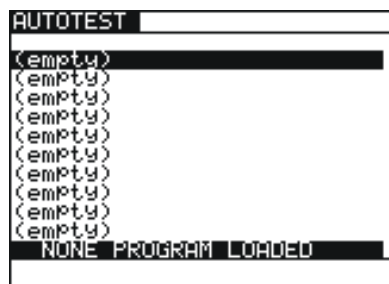

Fig. 45. Main menu in Autotest function (initially no program loaded)

STEP 4. Send programmed sequence to CE MultiTester from “List of instrument’s programs” menu by using **Send** button. After the transfer is completed the name of the user designed procedure is displayed on the list of programs. Up to 10 sequences can be sent to the instrument.

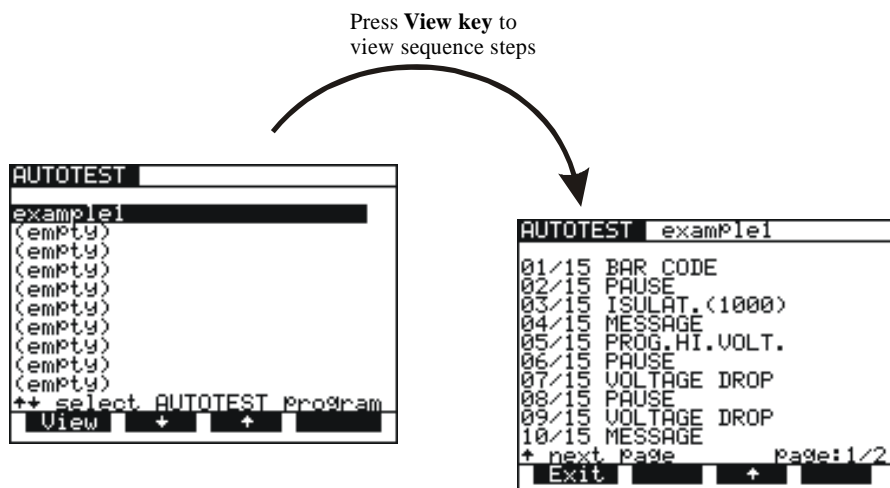

Fig. 46. Sequence name is displayed, to display individual steps press View key

STEP 5. Press **START/STOP** key to start the measurements that compose the sequence.

Note!

Keep the rotary switch unmoved until the execution of autotest sequence is finished, otherwise unpredicted results could be received!

SEQUENCE EXAMPLE

Sequence example illustrates usage of AUTOTEST function at testing Luminaries according to IEC 60598-1 standard.

- STEP 1.** BAR CODE READER (optional reading of bar code to memory).
- STEP 2.** PAUSE {(1 - 600) s or Wait for key} (to check device is ready for CONT test).
- STEP 3.** CONTINUITY 10 A {I: 10 A; Rlim: 0.5 E; time: 1 s}.
- STEP 4.** MESSAGE {ISO: **L+N to PE**} (notice to prepare device for ISO test).
- STEP 5.** INSULATION 500 V {Rlim: 2 M; time: 10 s}.
- STEP 6.** MESSAGE {HV: **L+N to grounded case**} (notice to prepare device for HV test).
- STEP 7.** WITHSTANDING {U: 1.5 kV; Ilim: 5 mA; time: 60 s}.
- STEP 8.** MESSAGE {HV: **L+N to nongr. case**} (notice to prepare device for HV test).
- STEP 9.** WITHSTANDING {U: 3.7 kV; Ilim: 5 mA; time: 60 s}.

STEP 10. WAIT FOR EXTERNAL INPUT sequence will be continued after external impulse.

STEP 11. DISCHARGE Internal {U: 60 V; t: 5 s}.

STEP 12. MESSAGE {LEAK.: L to PE; FUNCT.} (notice to prepare device for DISCH test and after PAUSE for FUNCT. Test).

STEP 13. LEAKAGE CURR. {Ilim: 1 mA; time: 5 s}.

STEP 14. PAUSE {2 s}.

STEP 15. FUNCTIONAL TEST {Plim: depend on luminary; t: 10 s}.

STEP 16. SOUND SIGNAL {t: 1 s} (notice after conclusion of testing).

STEP 17. MESSAGE {Testing successfully done}.

STEP 18. WAIT FOR EXTERNAL INPUT sequence will be continued after external user's signal.

STEP 19. PROGRAM SETTINGS {Luminary test 1}.

How to create sequence

Define all requested tests with their limits according to desired standard and tested device and arrange them into a sequence by logical order. Use PAUSE, MESSAGE, or WAIT FOR EXTERNAL INPUT functions between different tests to notify operator to prepare tested device for the appropriate following test.

Select **Auto repeat** option in Program settings to restart the sequence after it is done without pressing START button. Select **Save measurements** and **Auto send** options to send memorized results to PC after the sequence is done. CE Link enables to print Test Report after the results are received. All this functions together enable fully automated testing of products in production line.

It is possible to manufacture test accessory (relay matrix) for suitable connection between tested device and CE MultiTester. The equipment must be manufactured by customer according to their needs. It can be controlled by EXT output of CE MultiTester through PIN 3 (Wait for external input) input signal and PIN 4 (Next test) output signal.

FLOW CHART of SEQUENCE EXAMPLE

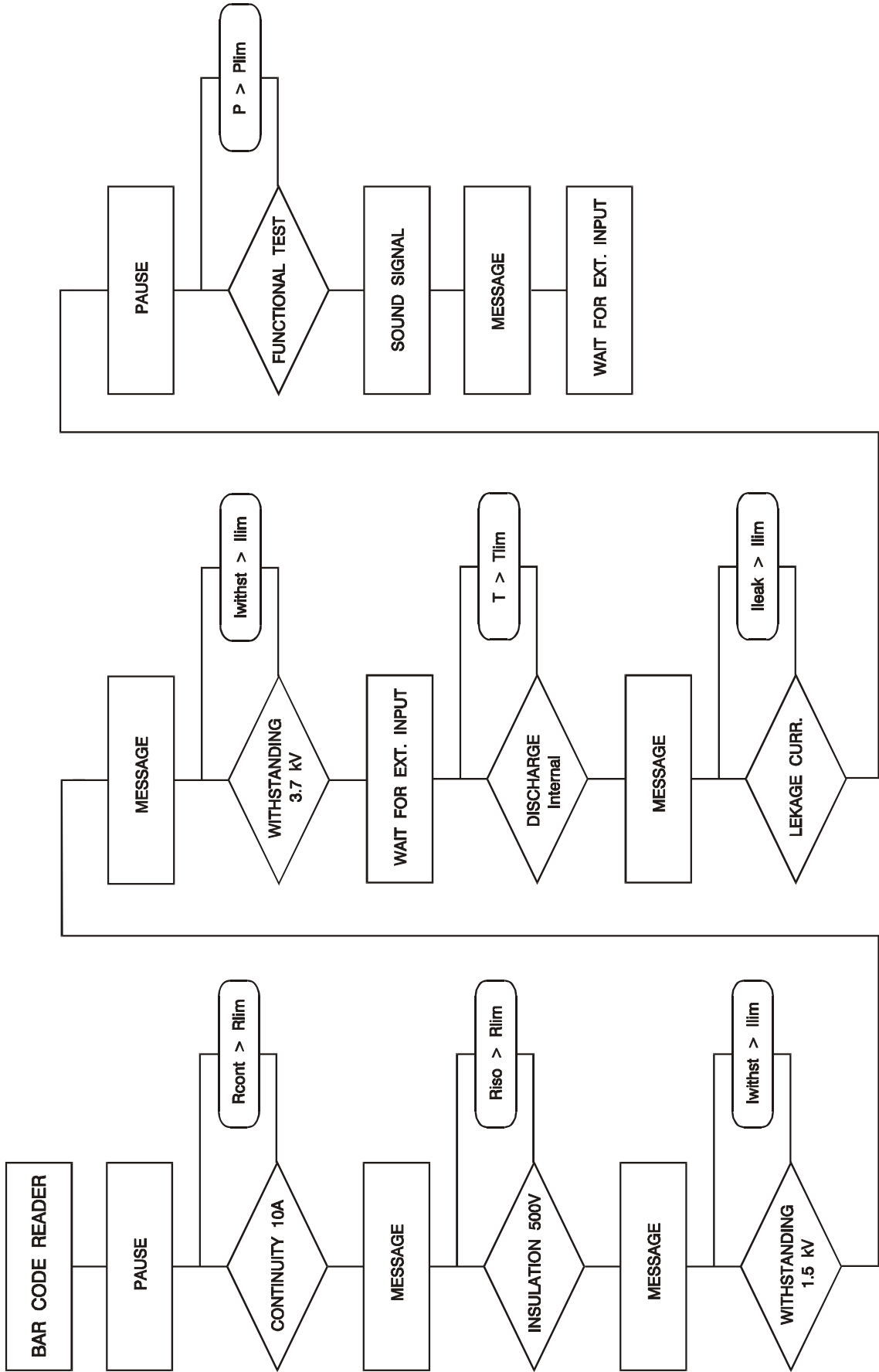

5. Operation

5.1. Warnings

Different warnings or information can be reported during manipulation with the CE MultiTester. Here is a list of warnings and information for each function.

HV and PROG.HV function:

Trip out..... The HV generator tripped-out due to the test current, which was higher than the set limit value.

Continuity function:

Load on TEST SOCKET External AC voltage connected to CONTINUITY
or
Voltage on term. C1-C2 input C1 – C2 (**voltage present on P1 and P2 too**), or
TEST SOCKET loaded.

Voltage on term. P1-P2 .. External AC voltage connected to CONTINUITY input
P1 – P2 is higher than 12 V (**voltage present on C1
and C2 too**).

Voltage drop function:

Load on TEST SOCKET External AC voltage connected to CONTINUITY
or
Voltage on term. C1-C2 input C1 – C2, (**voltage present on P1 and P2 too**) or
TEST SOCKET loaded .

Voltage on term. P1-P2 .. External AC voltage connected to CONTINUITY input
P1 – P2 is higher than 12 V (**voltage present on C1
and C2 too**).

ISO function:

Voltage on term. ISO External AC or DC voltage connected to ISO terminals
is higher than 30 V.

Discharging time function:

Ready displayed for approx. 1 s after pressing **START**.

Low Voltage .. displayed if the voltage on input mains is not appropriate or not
connected.

Start displayed if disconnection voltage is high enough to carry out
measurement, and the measurement will be performed.

Repeat repeat measurement.

Timeout displayed if the connection element is not pulled out in 10 s or
discharging time is higher then 10 s.

Over Voltage .. the voltage on input mains is higher than max. working voltage.

General:

HOT..... The instrument is overheated (CONTINUITY, VOLT.DROP, HV and PROG.HV);  sign is also displayed.

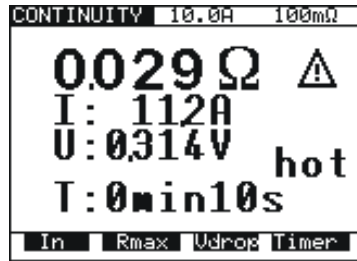



Fig. 47. Example of hot message

Measurements in functions ISO, LEAK.CURRENT, FUNCTION. TEST and DISC.TIME can still be carried out.

 **No Earth** .....Earth connection is missing on mains power plug.

No Voltage on TEST SOCKET..... Check Fuses F3, F4 (16 A T).

Load on TEST SOCKET..... Test socket is loaded in functions other than Leakage, Disc. time and Function. test.

Voltage on term. P1 - P2 Ext. AC voltage connected to P1-P2 input is higher than 12 V (**voltage present on C1 and C2 too**).

Voltage on term. ISO..... External AC or DC voltage connected to ISO terminals is higher than 30V.

5.2. Results memory

Each displayed result can be stored to one of 1638 memory locations. In addition to the main result all subresults and test parameters are also saved and can be recalled and downloaded to PC. Each result is marked with memory index (Memory:_____), device number (Device:_____) and device barcode number (Barcode:_____).

The device number can be set from 001 up to 255 and there are memory indexes that belong to each device, which can be set from 001 up to 1638 until the whole storage is occupied.

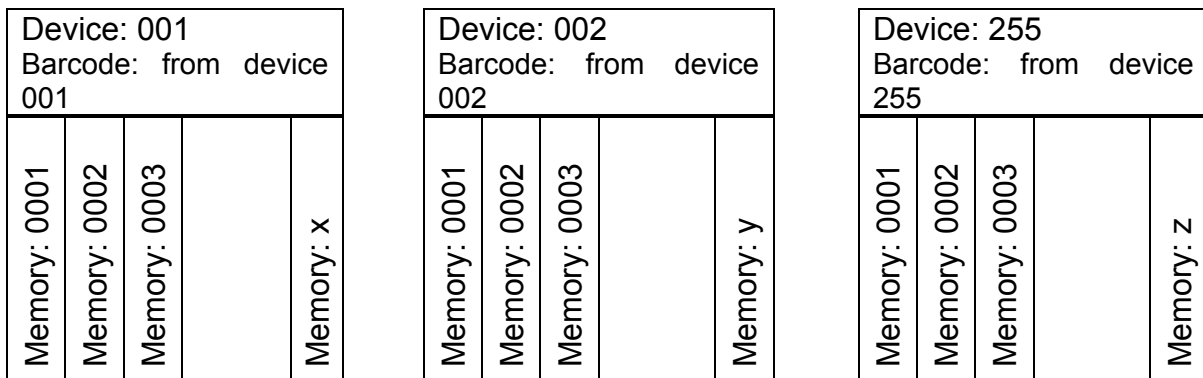

Fig. 48. Presentation of memory organization

How to save displayed results

The displayed result can be saved only after the measurement is complete.

STEP 1. Carry out the measurement.

STEP 2. Press **MEM** key in order to reach memory menu for saving results (see fig. below).

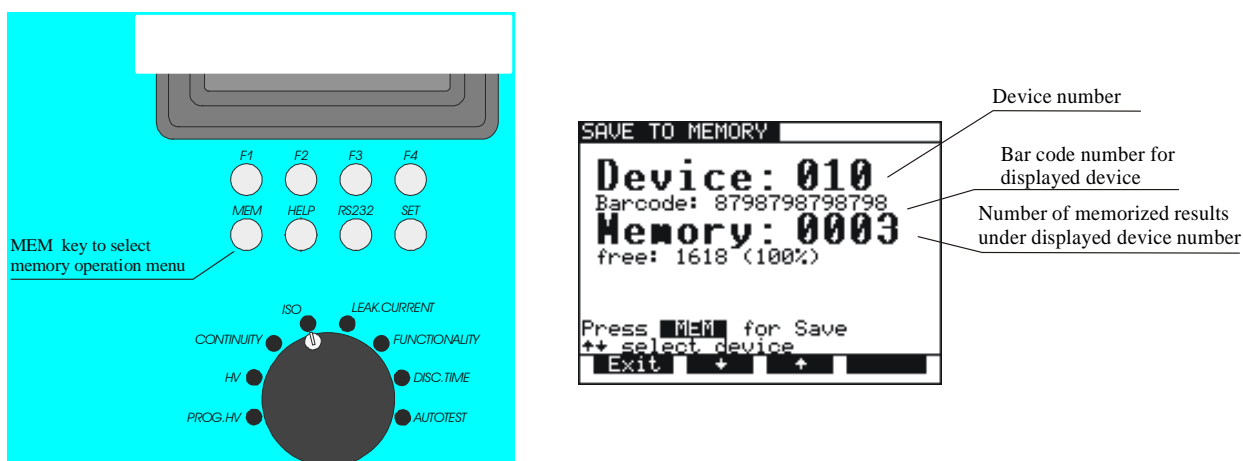

Fig. 49. Memory heading for saving results

STEP 3. Select device using \uparrow and \downarrow keys (default device is the last device used).

- Device number, Barcode from device and number of saved measurement on this device is displayed.
- See instruction in chapter 5.9. for how to get barcode number .

STEP 4. Press MEM key to save measured values / (Press Exit key to skip saving).

- After pressing MEM key memory menu will be automatically closed.

Note!

- Storing procedure can be easily accomplished by pressing MEM key twice when the user does not want to change the device (in this case the user can skip the procedure for device setting because the instrument will automatically set the last device used).
- Each displayed result can be stored only once (in order to avoid double storing by mistake).
- Any further pressing of MEM key will enable only memory recall (recall from memory menu will be displayed).
- The result of BURN test cannot be saved.
- In case the indication for full data memory appears, then stored results shall be transferred into PC and later complete data storage shall be erased. Deleting of particular results does not free memory space.

5.3. Recalling of stored results

The results can be recalled only before the measurement is performed or after the result is saved.

- STEP 1.** Press **MEM** key in order to reach memory menu for recalling results (see fig. below).

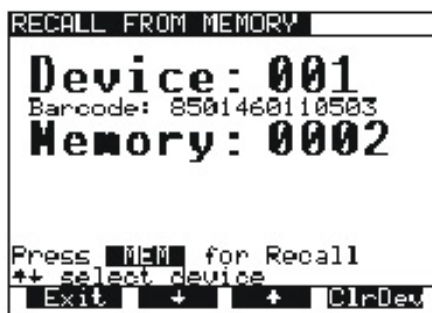

Fig. 50. Memory heading for recalling from memory

- STEP 2.** Select device using \uparrow and \downarrow keys.
- If for some reason the device has to be cleared press **ClrDev** key, (“press ClrDev to confirm” message will be displayed to prevent clearing by mistake). Press **ClrDev** key to confirm or **Exit** to cancel clearing procedure.

- STEP 3.** Press **MEM** key to recall saved results under chosen device.

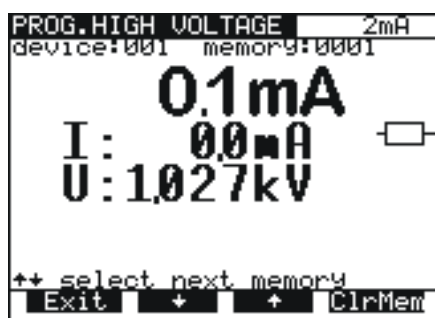

Fig. 51. Recalled result under device 001

- STEP 4.** Select result you are looking for by using \uparrow and \downarrow keys.
- To clear memory location press **ClrMem** key.

- STEP 5.** Press **Exit** key to exit menu.

5.4. Communication

In order to transfer stored data to PC, USB and/or RS 232 communication feature shall be used.

See 5.5. *System configuration* for communication set-up.

5.4.1. RS232 interface

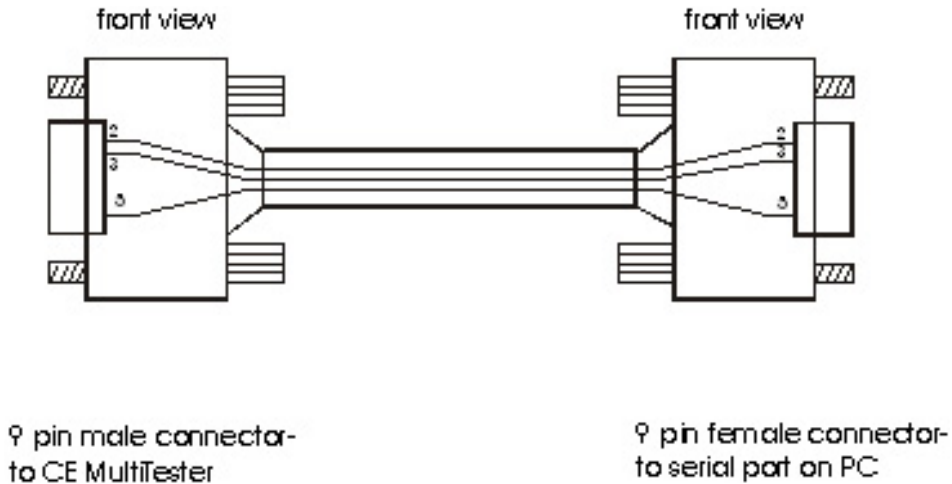

Fig. 52. RS 232 communication cable

Note!

Use original RS 232 communication cable or connect only pins on serial DB9 connectors according to Fig. 52 to avoid damages (pin 2, 3, 5).

5.4.2. Transferring the stored data to PC

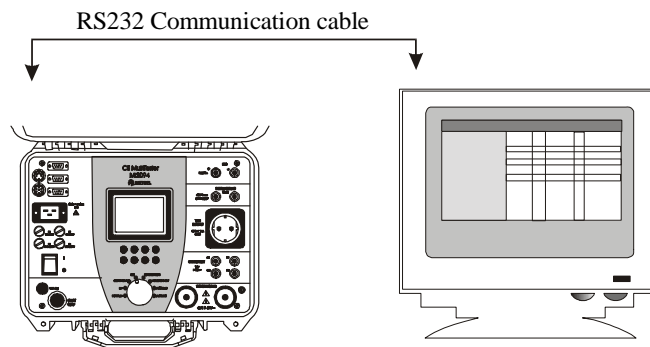

Fig. 53. Connection of CE MultiTester to PC by RS232 or USB interface cable

- STEP 1.** Connect CE MultiTester to PC as shown in fig. 53 using appropriate RS 232 or USB communication cable.
- STEP 2.** Open CE Link program on your PC.
- STEP 3.** Set baud rate (the same on PC and CE MultiTester).

STEP 4. Use ↑ and ↓ keys to select one of displayed options and press **Enter** key.

STEP 5. After pressing **Enter** key the selected function submenu is displayed at the bottom of menu:

Note!

USB drivers should be installed on PC before using the USB interface. Refer to USB installation instructions available on installation CD.

5.5. System configuration

To reach System configuration menu the following procedure must be carried out:

STEP 1. Switch off the instrument turning **ON/OFF** key to OFF position.

STEP 2. Press **SET UP** key and keep it pressed **while switching on** the instrument.

STEP 3. System configuration menu is displayed (see figure below).

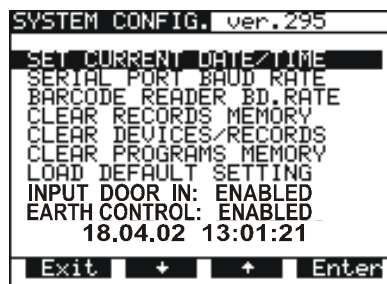

Fig. 54. Basic system configuration heading

STEP 4. Use ↑ and ↓ keys to select one of displayed options and press **Enter** key

STEP 5. After pressing **Enter** key on selected function message on the bottom of heading is displayed:



DATE and TIME setup:

- Use **Sel.** and ↑, ↓ keys to set **day, month, year, hour, minutes** and **seconds**. Year must be set manually at the beginning of each year when the time passes from 31.12 to 1.1. The warning "SYSTEM ERROR" is displayed otherwise.
- After **Exit** is selected the change will be confirmed and the main system menu is offered to allow selection of other functions or to exit to normal measuring mode.

```

SYSTEM CONFIG. ver.5.17ME
Hivolt.current L0limit
SET CURRENT DATE/TIME
SERIAL PORT MODE/RATE
BARCODE READER BD.RATE
CLEAR RECORDS MEMORY
CLEAR DEVICES/RECORDS
CLEAR PROGRAMS MEMORY
LOAD DEFAULT SETTING
INPUT DOOR IN: DISABLED
EARTH CONTROL: ENABLED
++ set limit: 4.0 mA
Exit  +  +

```

Low current limit in high voltage tests set-up:

The function is intended to warn the user that the current during HV test is lower than minimum expected. When enabled, LoLim indication is present and in a case that the test current is below the set limit, the warning sign appears.

- Press **EDIT** key to adjust low current limit.
- Use **Up / Down** keys to select or disable the current limit.
- After exit, the selected low current limit will be confirmed and basic HV test menus is displayed.

```

SYSTEM CONFIG. ver.5.14ME
Hivolt.current L0limit
SET CURRENT DATE/TIME
SERIAL POR. MODE/RATE
BARCODE READER BD.RATE
CLEAR RECORDS MEMORY
CLEAR DEVICES/RECORDS
CLEAR PROGRAMS MEMORY
LOAD DEFAULT SETTING
INPUT DOOR IN: DISABLED
EARTH CONTROL: DISABLED
USB 38.4 19.2 9.6
++
Exit Mode Rate

```

SERIAL COMMUNICATION PORT set-up:

- Use **Mode** key to select between USB and RS232.
- Use **Rate** key to select appropriate baud rate from 9600, 19200 or 38400.
- After exit, the selected communication port and new baud rate will be confirmed and basic menu is displayed.

```

SYSTEM CONFIG. ver.295
SET CURRENT DATE/TIME
SERIAL PORT BAUD RATE
BARCODE READER BU.RATE
CLEAR RECORDS MEMORY
CLEAR DEVICES/RECORDS
CLEAR PROGRAMS MEMORY
LOAD DEFAULT SETTING
INPUT DOOR IN: ENABLED
EARTH CONTROL: ENABLED
9.6 4.8 2.4
++
Exit Sel.

```

BARCODE READER BAUD RATE setup:

- Use **Sel.** keys to select appropriate baud rate from: 2400, 4800 or 9600.
- After exit, the new baud rate will be confirmed and basic menu is displayed.

```

SYSTEM CONFIG. ver.295
SET CURRENT DATE/TIME
SERIAL PORT BAUD RATE
BARCODE READER BU.RATE
CLEAR RECORDS MEMORY
CLEAR DEVICES/RECORDS
CLEAR PROGRAMS MEMORY
LOAD DEFAULT SETTING
INPUT DOOR IN: ENABLED
EARTH CONTROL: ENABLED
press ENTER for confirm
Exit Enter

```

CLEAR all RECORDS:

- Press **Enter** to confirm or **Exit** to cancel.

Note!

Device and bar code numbers will not be erased. To clear individual records use **Recall from memory** menu or CE link software.

CLEAR all DEVICES:

- Press **Enter** to confirm or **Exit** to cancel clearing of memory.

Note!

Before clearing, **download** all memorized results to PC

```

SYSTEM CONFIG. ver.295
SET CURRENT DATE/TIME
SERIAL PORT BAUD RATE
BARCODE READER BD.RATE
CLEAR RECORDS MEMORY
CLEAR DEVICES/RECORDS
CLEAR PROGRAMS MEMORY
LOAD DEFAULT SETTING
INPUT DOOR IN: ENABLED
EARTH CONTROL: ENABLED
press ENTER for confirm
Exit Enter

```

```

SYSTEM CONFIG. ver.295
SET CURRENT DATE/TIME
SERIAL PORT BAUD RATE
BARCODE READER BD.RATE
CLEAR RECORDS MEMORY
CLEAR DEVICES/RECORDS
CLEAR PROGRAMS MEMORY
LOAD DEFAULT SETTING
INPUT DOOR IN: ENABLED
EARTH CONTROL: ENABLED
press ENTER for confirm
Exit Enter

```

```

SYSTEM CONFIG. ver.295
SET CURRENT DATE/TIME
SERIAL PORT BAUD RATE
BARCODE READER BD.RATE
CLEAR RECORDS MEMORY
CLEAR DEVICES/RECORDS
CLEAR PROGRAMS MEMORY
LOAD DEFAULT SETTING
INPUT DOOR IN: DISABLED
EARTH CONTROL: ENABLED
18.04.02 13:01:21
Exit + + Enter

```

```

SYSTEM CONFIG. ver.295
SET CURRENT DATE/TIME
SERIAL PORT BAUD RATE
BARCODE READER BD.RATE
CLEAR RECORDS MEMORY
CLEAR DEVICES/RECORDS
CLEAR PROGRAMS MEMORY
LOAD DEFAULT SETTING
INPUT DOOR IN: ENABLED
EARTH CONTROL: DISABLED
18.04.02 13:01:21
Exit + + Enter

```

to avoid losing important data.

CLEAR all PROGRAMS:

- Press **Enter** to confirm or **Exit** to cancel clearing of memory.

Note!

Before clearing, **download** all memorized results to PC to avoid losing important data.

LOAD DEFAULT SETTING

Sets all adjustable test parameters to their initial values.

- Press **Enter** key to confirm or **Exit** key to exit.

INPUT DOOR IN:

Enables or to disables DOOR IN input.

- After selecting this option press **Enter** to switch between ENABLE and DISABLE

EARTH CONTROL:

If one wishes to enable or to disable EARTH CONTROL .

- After selecting this option press enter to switch between ENABLE and DISABLE

Note!

It is advisable to disable this option only in protected IT systems. For TN systems you should always enable it.

List of test parameters for each function, and their initial values:

Function	Parameter	Range of adjustment or possible values	Initial value
PROG.HV	U_N test voltage	100 V ÷ 5 kV ~	$U_1=1$ kV $U_2=3,7$ kV
	I_{max} tripping current	(0.5, 1.0, 1.5 2.0, 2.5, 3.0, 3.5, 4.0, 4.5, 5.0, 5.5, 6.0, 6.5, 7.0, 7.5, 8.0, 8.5, 9.0, 9.5, 10, 20, 30, 40, 50, 60, 70, 80, 90, 100, 150, 200, 250, 300, 350, 400, 450, 500) mA	2 mA
	T timer	1 s - 240 s with resolution 1 s	$T_1=10$ s $T_2=10$ s $T_3=10$ s
	LowLim low limit current	DISABLE, 0.1 mA .. 25.5 mA	any
HV	U_N test voltage (for I limit and burn mode)	100 V ÷ 5 kV ~	1 kV
	I_{max} tripping current	(0.5, 1.0, 1.5 2.0, 2.5, 3.0, 3.5, 4.0, 4.5, 5.0, 5.5, 6.0, 6.5, 7.0, 7.5, 8.0, 8.5, 9.0, 9.5, 10, 20, 30, 40, 50, 60, 70, 80, 90, 100, 150, 200, 250, 300, 350, 400, 450, 500) mA	2 mA
	T timer	1 s - 9 min 59 s with resolution 1 s	10 s
	LowLim low limit current	DISABLE, 0.1 mA .. 25.5 mA	any
Continuity	I_N test current	100 mA, 200 mA, 10 A, 25 A~	10 A
	R_{max} max. allowed resistance	(10 - 990) m Ω (by steps of 10 m Ω) (1000 - 2000) m Ω (by steps of 100 m Ω) or *** Ω (no limit)	100 m Ω
	t timer	(1 - 59) s	10 s
Voltage Drop	ΔU_{max} max. allowed voltage drop	5.0 V (0.50 mm ²), 5.0V (0.75 mm ²), 3.3 V (1.0 mm ²), 2.6V (1.5 mm ²), 1.9 V (2.5 mm ²), 1.4V (4.0 mm ²), 1.0 V \geq 6.0 mm ²	3.3 V (1 mm ²)
	t timer	(1 - 59) s	10 s
ISO	U_N test voltage	250 V, 500 V, 1000V =	500 V =
	R_{min} min. allowed insulation resistance	(0.2 - 9.9) M Ω (by steps of 0.1 M Ω) (10 - 200) M Ω (by steps of 1 M Ω) or *** M Ω (no limit)	1 M Ω
	t timer	1 s - 9 min 59 s with resolution 1 s	10 s
Leakage	I_{max} limit current	(0.00 - 20.0) mA	1m A
	t timer	1 s - 9 min 59 s with resolution 1 s	10 s
Touch Leakage	I_{max} limit current	(0.00 - 2.00) mA	1mA
	t timer	1 s - 9 min 59 s with resolution 1 s	10 s

Function	Parameter	Range of adjustment or possible values	Initial value
Substitute Leakage	I _{max} limit current	(0.00 - 20.0) mA	1mA
	t timer	1 s - 9 min 59 s with resolution 1 s	10 s
Function. test	S _{max} limit power	(10 - 3500) VA	1000 VA
	t timer	1 s - 9 min 59 s with resolution 1s	10 s
DISC. TIME	Syst measuring system	external (1 s), internal (5 s)	external (1 s)
	t timer ON/OFF	ON or OFF	ON
All functions	RS232 baud rate	9600, 19200, 38400	38400
	Barcode r. baud rate	2400, 4800, 9600	9600
	Contrast	(0 - 100) % (by steps of 2 %)	50 %

5.6. Contrast of the display

Where there is insufficient readability of the display (display too dark or intensity of messages too weak), the appropriate contrast of the display should be set.

How to set appropriate contrast

It is possible to adjust contrast in all positions of main switch.

STEP 1. Press **SET** key together with **F3** to make the display darker or together with **F2** to make the display brighter (keep the keys pressed until the desired contrast is achieved)

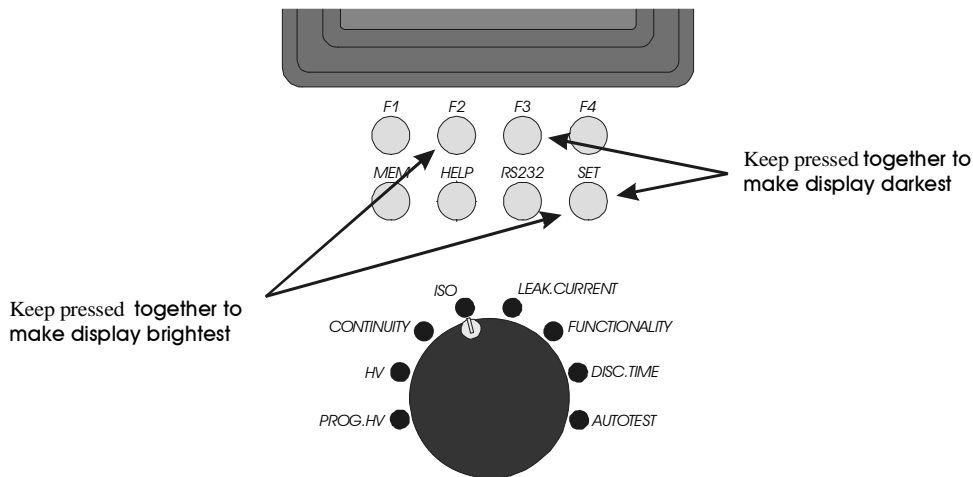

Fig. 55. How to set appropriate contrast

Note!

The selected contrast may change due to a change in temperature of the display (instrument heat or changed ambient temperature).

5.7. Use of remote control pedal

The pedal is intended to start and stop the measurement (in each function) as well as to save displayed results by foot. It is advisable to use the pedal when both hands are occupied with test probes, or when tests are to be carried out away from the instrument using longer test cables.

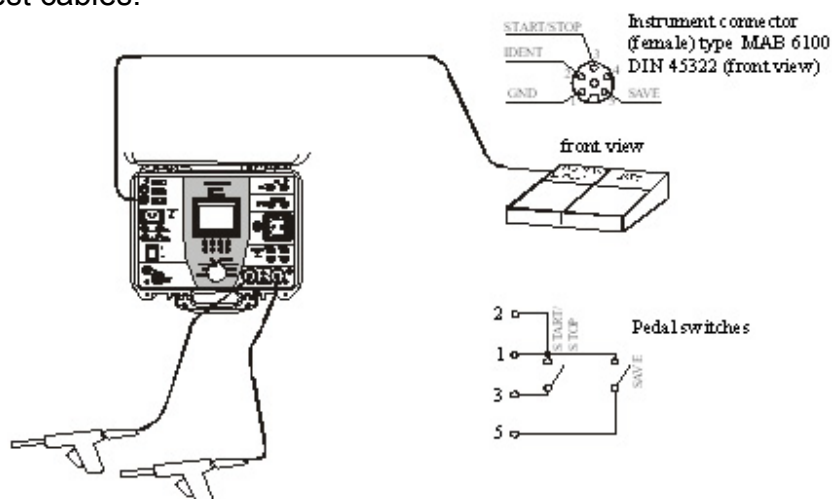

Fig. 56. Connection of remote control pedal to CE MultiTester

Note!

The selected contrast may change due to a change in temperature of the display (instrument heat or changed ambient temperature).

How to operate REMOTE CONTROL pedal

START/STOP function on the pedal is exactly the same as on front panel of the instrument when the pedal is not connected.

SAVE function on the pedal is automatic, so a double press to SAVE pedal is required to save displayed result to the next location of set device number. The device number must be set in advance. If you press **SAVE** more than twice, the instrument will throw into **Recall** function and you cannot exit it by using REMOTE PEDAL. You can exit this function only by pressing front panel key on the instrument.

The following procedure is to be used:

- STEP 1.** Connect REMOTE CONTROL pedal to the instrument as it is shown in fig.56 and carry out the measurement by pressing START/STOP pedal.
- STEP 2.** Save the first result to desired memory location (memory number and device number) using front panel keys, see the instructions in chapter 5.2.
- STEP 3.** Carry out the next test using START/STOP pedal.

STEP 4. Save the result by pressing SAVE pedal twice.

STEP 5. Proceed with the measurements.

Technical specifications of the pedal:

- Cable length 10 m
- Commands.....START/STOP, SAVE
- Casing.....metal
- Weight.....2 kg
- Size (W×H×D)(300 × 55 × 175) mm

5.8. Use of WARNING LAMP

The lamp is intended to inform the user if dangerous voltages are present when WITHSTANDING tests are carried out (HV and PROG.HV position).

Meaning of each lamp:

- Red (TEST) lamp **on** means that dangerous voltage is present at WITHSTANDING test terminals. **Take care when using test pistols!**
- Green (READY) lamp **on** means that the instrument is ready for the next measurement, dangerous voltage is not present at WITHSTANDING test terminals.

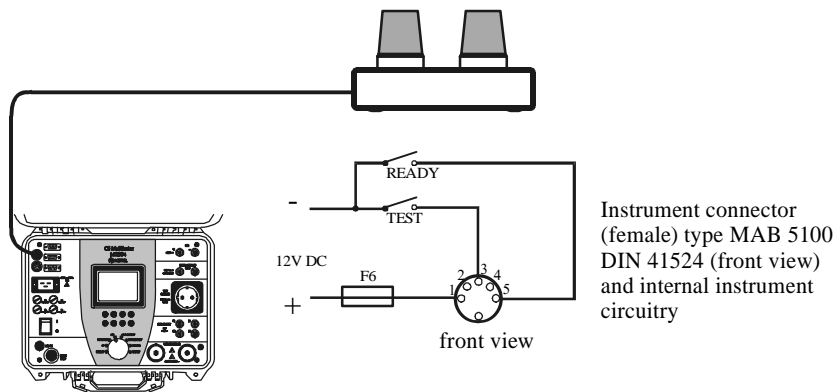

Fig. 57. Connection of warning lamp to CE MultiTester

Technical specifications of the WARNING LAMP:

- Cable length 1 m
- Lamp bulbs(12 - 15) V / 4 W, producer RAFI, Order No. 1.90020.104
- Casing.....plastic
- Weight.....0.3 kg
- Size (W×H×D)(200 × 95 × 110) mm

Note!

If no lamp lights when rotary switch is in HV position, stop the measurements immediately and check the WARNING LAMP connection and light bulbs.

5.9. Use of barcode reader

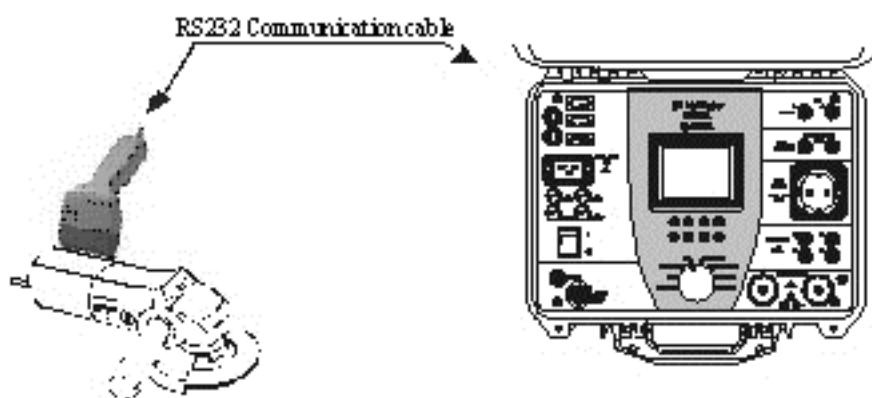

Fig. 58. Connection of barcode reader to CE MultiTester

Use a barcode reader that includes RS232 communication with DB9 (male) connector. Select baud rate for barcode reader (see chapter 5.5 System configuration)

To add a barcode number to the currently enabled device use serial barcode reader. This operation is allowed in all measuring positions before or after the measurement.

After this action in memory menu, the bar code number is displayed together with device number and number of saved results.

Following barcode standards are supported: EAN 13, CODE 39 and CODE 128.

(Only barcodes of size 4 to 13 signs can be read).

5.10. Use of EXT/DOOR input

Specification of EXT. / DOOR IN signals:

Pin 2: Pass / Fail	(digital output)
Pin 3: External input	(digital input)
Pin 4: Next test	(digital output)
Pin 5: Door in	(digital input)
Pin 6: Gnd	

5.10.1. DOOR input

If the DOOR IN input is enabled (see chapter 5.5 – System configuration), tests in PROG. HV and HV position will not be started until the door is not open. See figure below to connect DOOR IN signal to CE MultiTester.

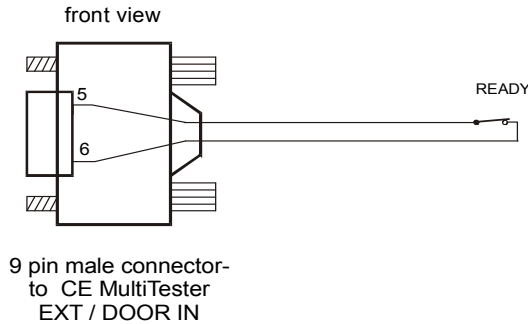

Fig. 59. Connection of DOOR IN signal to CE MultiTester

5.10.2 EXTERNAL input

EXT port is intended to:

- show the result (PASS / FAIL) of measurement,
- give information during sequenced measurements (for AUTOTEST sequence),
 - allow external control of AUTOTEST sequence execution.

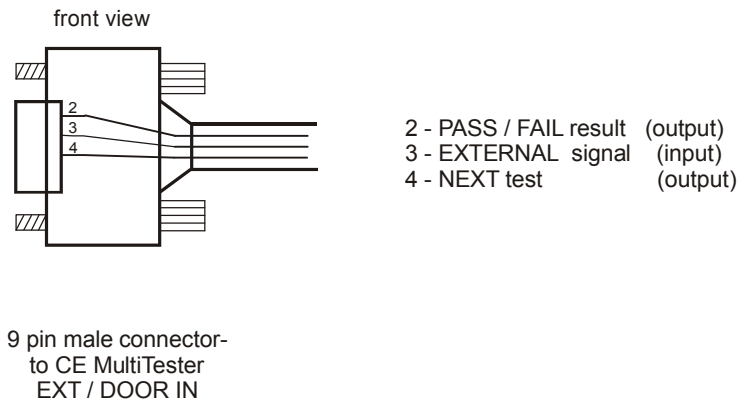

Fig. 60. Signals of EXT port

PASS / FAIL:

In autotest and individual measurements the status of measurement (PASS / FAIL) is given on pin 2 of EXT / DOOR IN connector. If the measurement result is inside the range of limit then pin 2 is **HI level**. If the measurement is out of limit range then pin 2 is **LO level**.

- pin 2 – HI level:* - the next program step of the autotest will be executed
- pin 2 – LO level:* - press START key to restart measurement
- press **Skip** key - program will continue with the next step

- press **Exit** key to stop program execution and return to AUTOTEST menu

External:

Pin 3 of DOOR IN input is supported by Autotest program command 'Wait for external input'.

Generally the user can define four different kind of pause between two sequent measurements.

1. *Predefined time pause* - common equal pause between measurements (it can be set from 1 s to 5 s in sequence editor: Program name / Pause).
2. *Time pause* – it has to be inserted as a 'Pause' command as the last command in the *.SQC program. In this case the total pause between two sequent measurements is predefined time pause + Time of 'Pause' command.
3. *Message* - it has to be inserted as a 'Message' command in the *.SQC program. The instrument waits for the user reaction (connect test leads to tested object and press START).
4. *Wait for external input* – this command waits for change from HI to LO on pin 3 of DOOR / IN input (see figure below.)

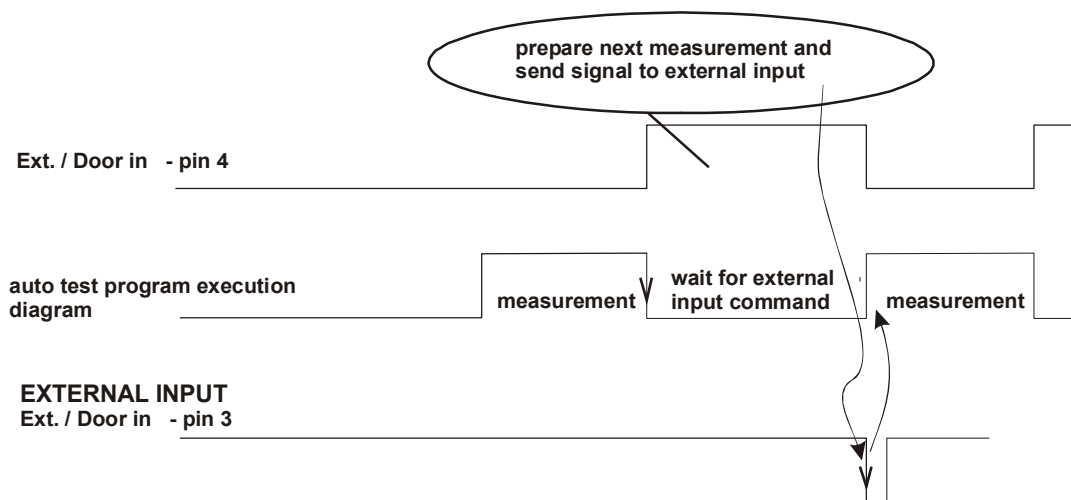

Fig. 61. Wait for external input diagram

Application example – unpredictable pause time for the same action (manual action is part of preparation for another measurement).

Next test:

Pin 4 indicates the end of execution of each measurement (change from LO to HI). Immediately after the start of another measurement it changes from HI to LO state.

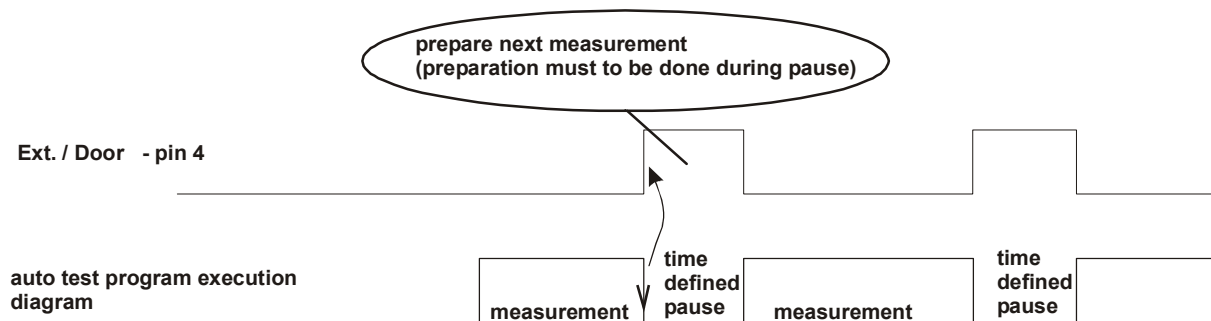

Fig.62. Next test signal diagram

6. Maintenance

6.1. Metrological check

It is essential that all measurement instruments are regularly calibrated. We recommend an annual calibration to be carried out.

6.2. Service

Repairs under or out of guarantee: Please return the products to your distributor.

6.3. Cleaning

To clean the surface of the instrument, use a soft cloth slightly moistened with soapy water or alcohol. Then leave the instrument to dry totally before use.

- **Do not use liquids based on petrol or hydrocarbons!**
- **Do not spill cleaning liquid over the instrument! Always moisten the cloth and then clean the instrument!**

6.4. Replacing the fuses (properly trained service personnel only!)

In the case of instrument malfunction send the instrument to the appropriate service center for all four fuses to be checked.

See the purpose of each fuse in paragraph 3.9.

Use original fuses only as declared in paragraph 3.9!



..... Disconnect all test cables and mains cord before opening the instrument.



..... Hazardous voltage may be present inside the instrument.

Properly trained service personnel only should carry out operation.

Position of fuses inside instrument:

F5 T 32 A (10.3x38) mm 400 V~ (inside instrument on front panel, protects continuity circuitry)

F6 F 500 mA / 250 V (on main PCB board, protects warning lamps outputs)

Manufacturer address:

METREL d.d. Ljubljanska 77, SI-1354 Horjul

Tel: +(386) 1 75 58 200

Fax: +(386) 1 75 49 095

Email: metrel@metrel.si

**The instrument contains no user serviceable parts.
Only an authorized dealer is allowed to carry out service
or calibration!**

7. PC Software - CE Link

7.1. Installing CE Link

- CE Link software is 32-bit application for Windows platforms.
- Before installing CE Link it is recommended to close all running programs on your PC. After installation is complete there is no need to restart computer
- Insert installation disc in your computer and run SETUP.EXE.
- Standard Install Shield Wizard will guide you through installing process.
- Program will be installed in directory "C:\Program Files\CE Link" or in directory you select.
- After installation is done you are able to run CE Link.exe from Start menu.

WARNING:

This program is protected by copyright law and international treaties.

Unauthorized reproduction or distribution of this program, or any portion of it, may result in severe civil and criminal penalties, and will be prosecuted to the maximum possible under law.

7.2. Introduction notes

CE MultiTester has a powerful Windows platform support tool – "CE Link". It is used for downloading of recorded data, additional analyzing of recorded data, for creating measurement sequences, for creating report documentation, and more.

When opening CE Link for the first time, set Password in Settings menu (to enable communication between PC and instrument). Otherwise Demo mode is selected.

To set password enter password into Code column. With one software is possible to communicate with 10 instruments (but it is necessary to insert code numbers for all instruments)

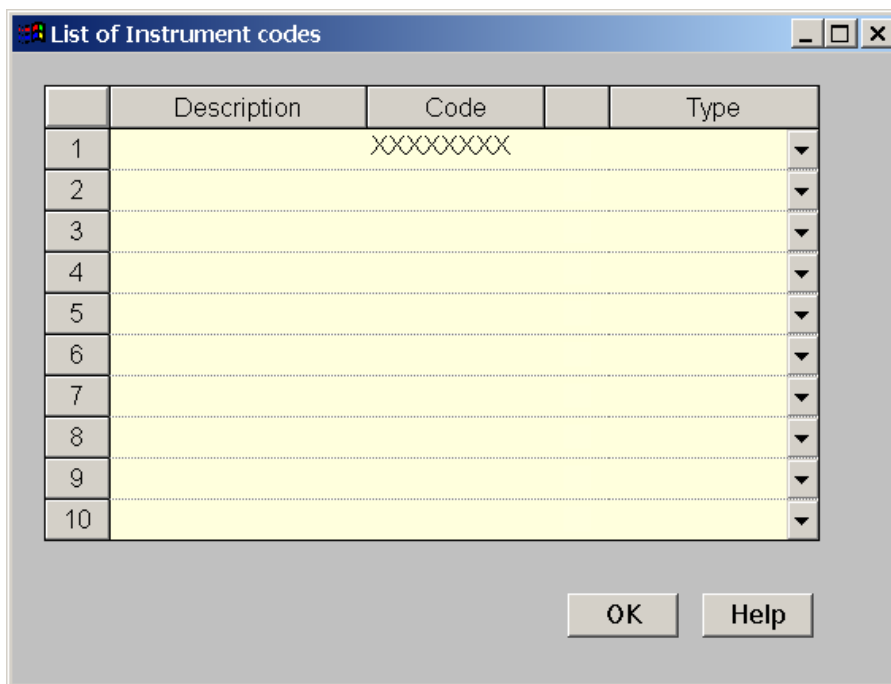

Fig. 63 Code settings window

Basic screen is start point for all actions.

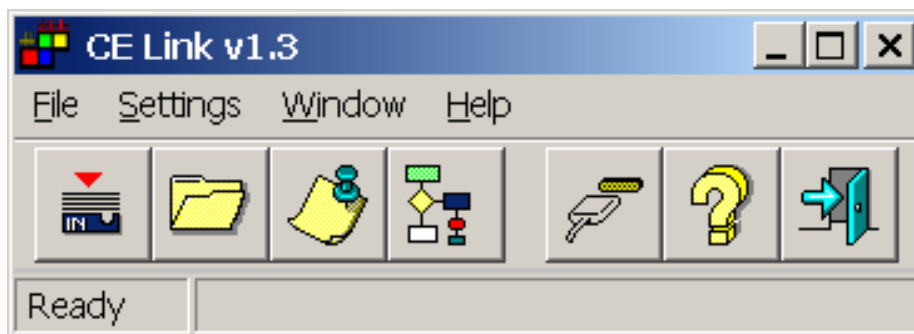

Fig. 64. Basic screen





	<p>Download data: Opens window for downloading or auto-downloading data from CE MultiTester to PC.</p> <p>Shortcut key: Alt F + D</p>		<p>Port settings: Opens window for port and baud rate settings.</p> <p>Shortcut key: Alt S + P</p>
	<p>Open data file: Opens window for analyzing recorded data file.</p> <p>Shortcut key: Alt F + O</p>		<p>Help: Opens help window.</p> <p>Shortcut key: Alt H</p>
	<p>Header programming: With this tool user can define header for printed documents.</p> <p>Shortcut key: Alt F + H</p>		<p>Exit: Exits CE Link.</p> <p>Shortcut key: Alt F + E</p>
	<p>Sequence editor: Tool for programming AUTOTEST sequences.</p> <p>Shortcut key: Alt F + S</p>		

Table. 1. Fast access buttons

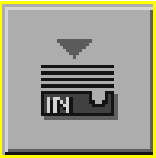

7.3. Download data

Before starting “Download data” window it is necessary to:

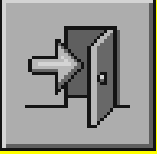
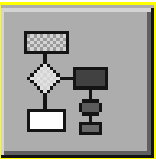
- Connect CE MULTITESTER to PC according to figure 53 (chapter 5.4. RS 232 Communication) using appropriate RS 232 communication cable (Fig. 52).
- check et baud rate (same value must be set in CE Link and CE MultiTester is necessary)
 - Set baud rate in CE Link software by using **Port settings** window.

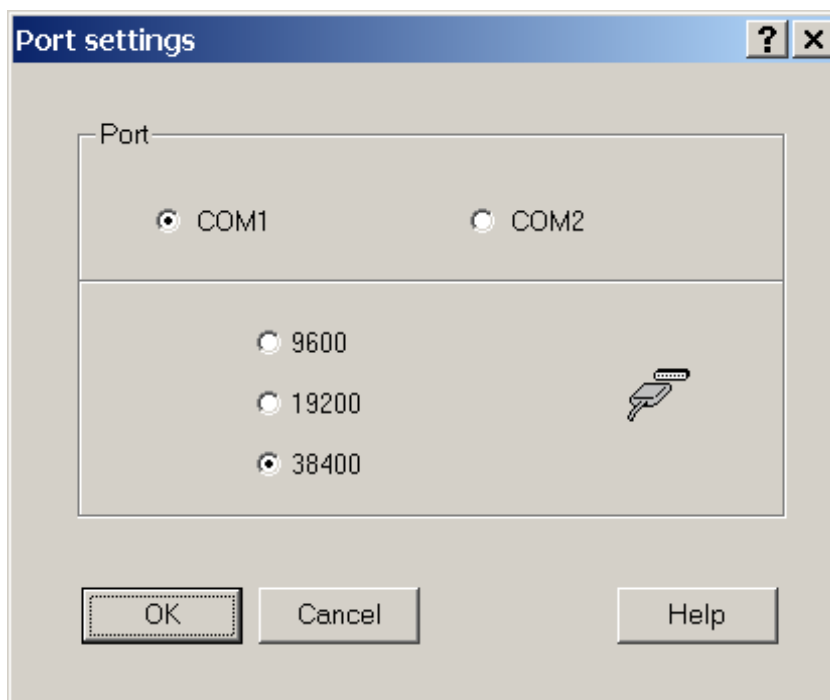

Fig. 65. Port settings window

- Check baud rate on CE MultiTester by using **SET** key (see SERIAL PORT BAUD RATE setup in SYTEM CONFIGURATION in chapter 5.5)
- Prepare CE MULTITESTER for communication by pressing **RS232** key (instrument will go in communication mode).
- Choose Download \ Standard download data option in main CE Link window

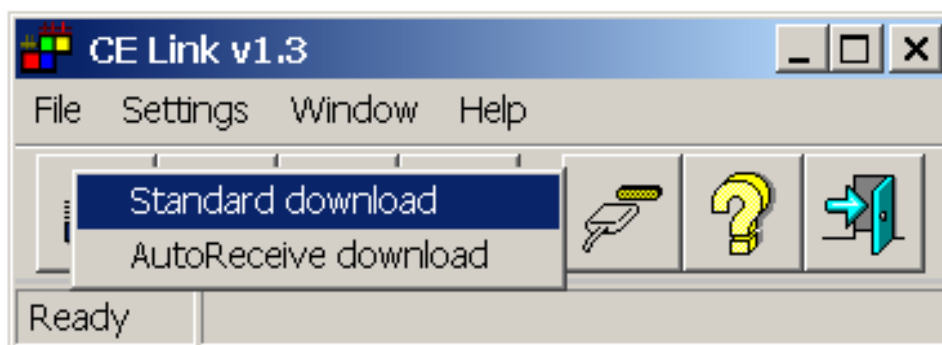

Fig. 66. Standard download mode

- After message “Downloading in progress...” is displayed and if the downloading is done successfully, the user will define name for this data file and it will be saved on disc in desired folder by pressing **Save** key.

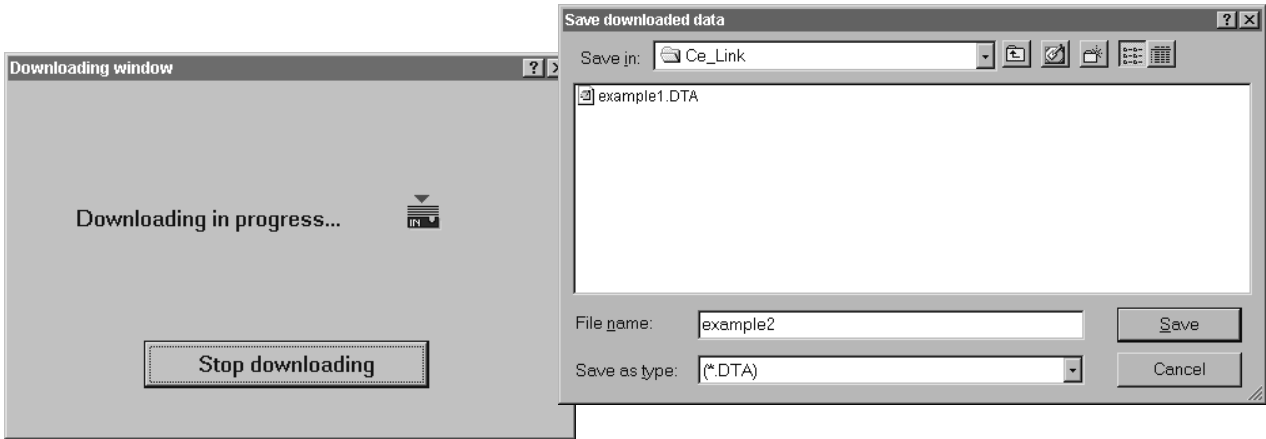

Fig. 67. Downloading data windows

- For auto download from instrument (instrument must be in the **Autotest mode**) choose **AutoReceive download** option. In this mode PC waits to receive record from the instrument. Instrument sends record to the PC at the end of each sequence procedure. After downloading the sequence will be executed again. For details of sequence creating see chapter **7.6 Sequence editor** (in program definition window AutoSend option has to be enabled)

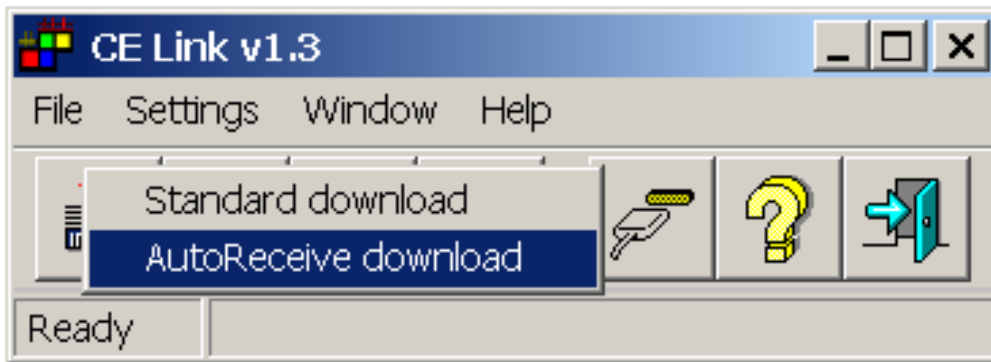

Fig. 68. Auto receive download mode

- After the file name for storing downloaded data is defined the 'Auto receive mode' window will appear

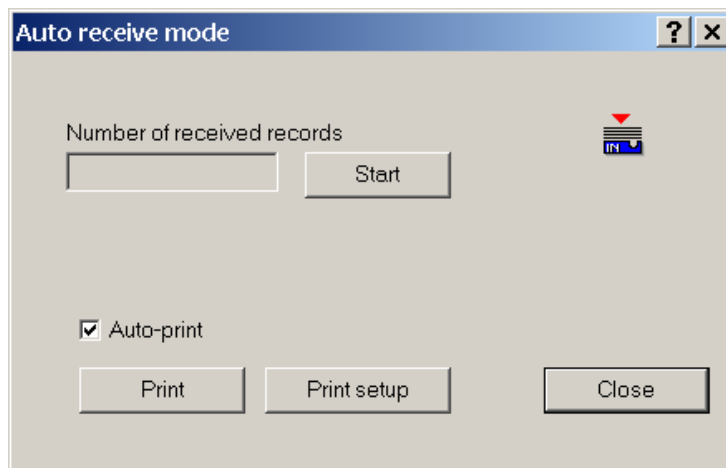

Fig. 69. Auto receive download mode

- Before starting of the autotest you should press **Start** button in the Auto receive mode window.
There is a counter for the number of received records since **Start** pressed.
- Auto receive mode enables two different ways for printing received results:
 - Auto print (automatically prints the results after each reception)
 - Manual print (print results after **Print** button in the Auto receive mode is pressed)
- At the end of auto download you should press **Stop** button in the **Auto receive mode** window.



7.4. Open data file

To open one of downloaded data files press “Open data file” button in basic screen. Window for file selection will be displayed.

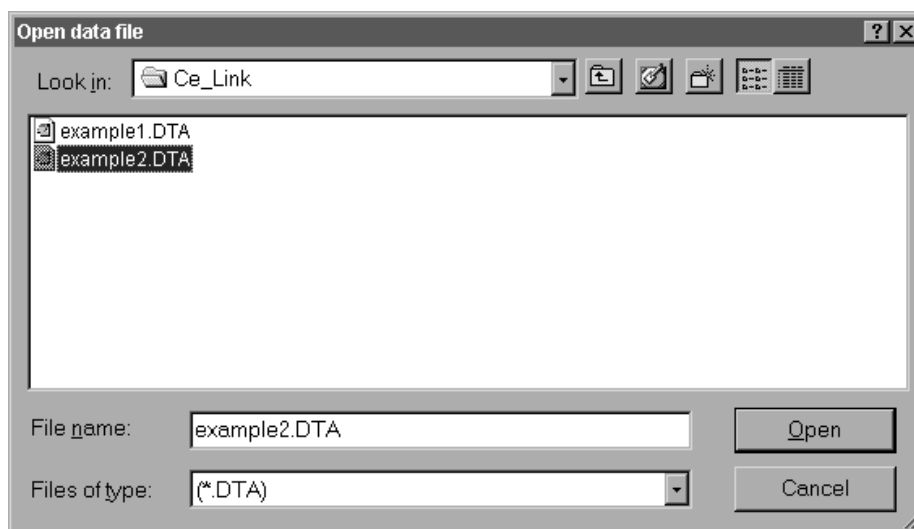

Fig. 70. Selecting file “example2. DTA”

After selecting the desired data file and pressing **Open** downloaded data will be displayed in the table form. Table organization is same as in instruments internal memory; from Device 1 to last Device (max 255) with saved results, - see chapter 5.2. Memorizing of results.





Time	Dev	Mem	Description	Result 1	Result 2	Result 3	Result 4	Result 5
18.05.00: 13:21:45	1	0	Leakage current	I: 0.05mA		t: 3s	IL: 1.00mA	
18.05.00: 13:21:54		1	Leakage current	I: 0.05mA		t: 5s	IL: 1.00mA	
18.05.00: 13:22:00		2	Leakage current	I: 0.05mA		t: 2s	IL: 1.00mA	
18.05.00: 13:22:09		3	Leakage current	I: 0.05mA		t: 5s	IL: 1.00mA	
18.05.00: 13:22:21		4	Leakage current	I: 0.05mA		t: 8s	IL: 1.00mA	
18.05.00: 13:24:54		5	Riso 500V	R > 999.90hm	U: 530V	t: 0s	RL: 3277.8MOhm	
22.05.00: 11:48:23	2	0	Riso 500V	R: 1.007Ohm	U: 144V	t: 4s	RL: 32.778MOhm	
22.05.00: 11:48:47		1	Riso 500V	R: 1.007Ohm	U: 144V	t: 3s	RL: 32.778MOhm	
22.05.00: 11:48:57		2	Leakage current	I: 0.13mA		t: 3s	IL: 1.00mA	
22.05.00: 11:49:04		3	Leakage current	I: 0.13mA		t: 3s	IL: 1.00mA	
22.05.00: 11:49:16		4	Cont. Current/Rmax	R: 0.034Ohm	I: 11.3A	U: 0.364V	t: 3s	RL: 0.010Ohm
22.05.00: 11:49:24		5	Cont. Current/Rmax	R: 0.032Ohm	I: 11.0A	U: 0.335V	t: 4s	RL: 0.010Ohm
22.05.00: 11:49:33		6	With. high voltage	I: 0.3mA	U: 1.033kV	t: 3s	IL: 1.0mA	
22.05.00: 11:49:43	3	0	With. prog. high voltage	I: 0.2mA	U: 1.035kV	t: 10s	IL: 2.0mA	
22.05.00: 11:49:58		1	With. high voltage	I: 0.3mA	U: 1.031kV	t: 3s	IL: 1.0mA	

Fig. 71. Data file window

In the table all failed measurements will be marked by red color. By using search button (see table 2) the user can easily jump from one to another failed measurement.

For table editing (for example if a measurement result is saved during measuring under wrong device index by mistake) standard utilities are available, such as copy, cut, paste, delete etc. All those operations affect selected row.

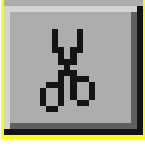
After table editing device and memory numbers can be rearranged from top to bottom by pressing **Rearrange** button.

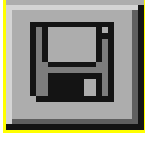
	<p>Copy: Copies selected row. Shortcut key: Ctrl+C, Alt E + C</p>		<p>New / Edit Device: Adds description, edits device or barcode number or creates new device. Shortcut key: Alt E + N</p>
	<p>Cut: Cuts selected row. Shortcut key: Ctrl+X, Alt E + U</p>		<p>Insert / Edit comment: Inserts row with comment or edit existed comment. Shortcut key: Alt E + O</p>
	<p>Paste: Paste last cut or copied row. Shortcut key: Ctrl+V, Alt E + P</p>		<p>Save table: To save edited table. Shortcut key: Alt F+S</p>



	<p>Delete: Deletes selected row (after delete paste is not available).</p> <p>Shortcut key: Delete, Alt E + S</p>		<p>Export to clipboard: Exports selected rows on clipboard.</p> <p>Shortcut key: Alt E</p>
	<p>Mark / Unmark row: Marks or unmarks important row.</p> <p>Shortcut key: Alt E + D</p>		<p>Print: Prints open data file.</p> <p>Shortcut key: Alt F + P</p>
	<p>ReArrange numbers: Rearranges from top to bottom device and memory numbers (often used after editing table).</p> <p>Shortcut key: Alt E + R</p>		<p>Main window: Jumps to main window without closing.</p> <p>Shortcut key: Alt F + M</p>
	<p>Search: Jumps on next row with error value.</p> <p>Shortcut key: Alt E + S</p>		<p>Close: Closes window and return to main window.</p> <p>Shortcut key: Alt F + C</p>

Table. 2. Fast access buttons

The user can insert a new row with comment or edit existing comments (**Insert / Edit comment** button). To export measurement to other programs, the user can use **Export to clipboard** option (Copy / Paste commands do not work with Windows clipboard). Note: only selected rows will be exported.

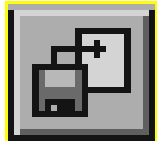
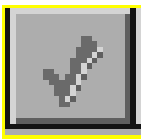

7.5. Printing documents

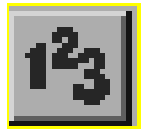
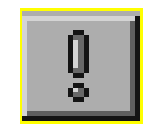
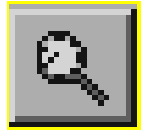
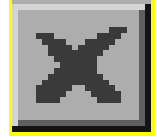
7.5.1 Printing selected rows

Selected rows can be printed following this steps:

1. Select rows to be printed (use **Shift + left** mouse button for selecting subsequent records to record or **Ctrl + left** mouse button for selecting one row by one).
2. Choose **Window for printing** option in **File** men.
3. To create header select **Define header** in **File** menu.
4. Choose **Print** form **Print** menu.

Header options

- define header height,
- include bitmap file (user logo - in our example windows clouds.bmp),
- underline header,
- write header text (first line above bitmap, other five under), for every line set appropriate font or insert commands like system date, time, serial number, current page, total pages,
- load or save created header,
- preview created document.

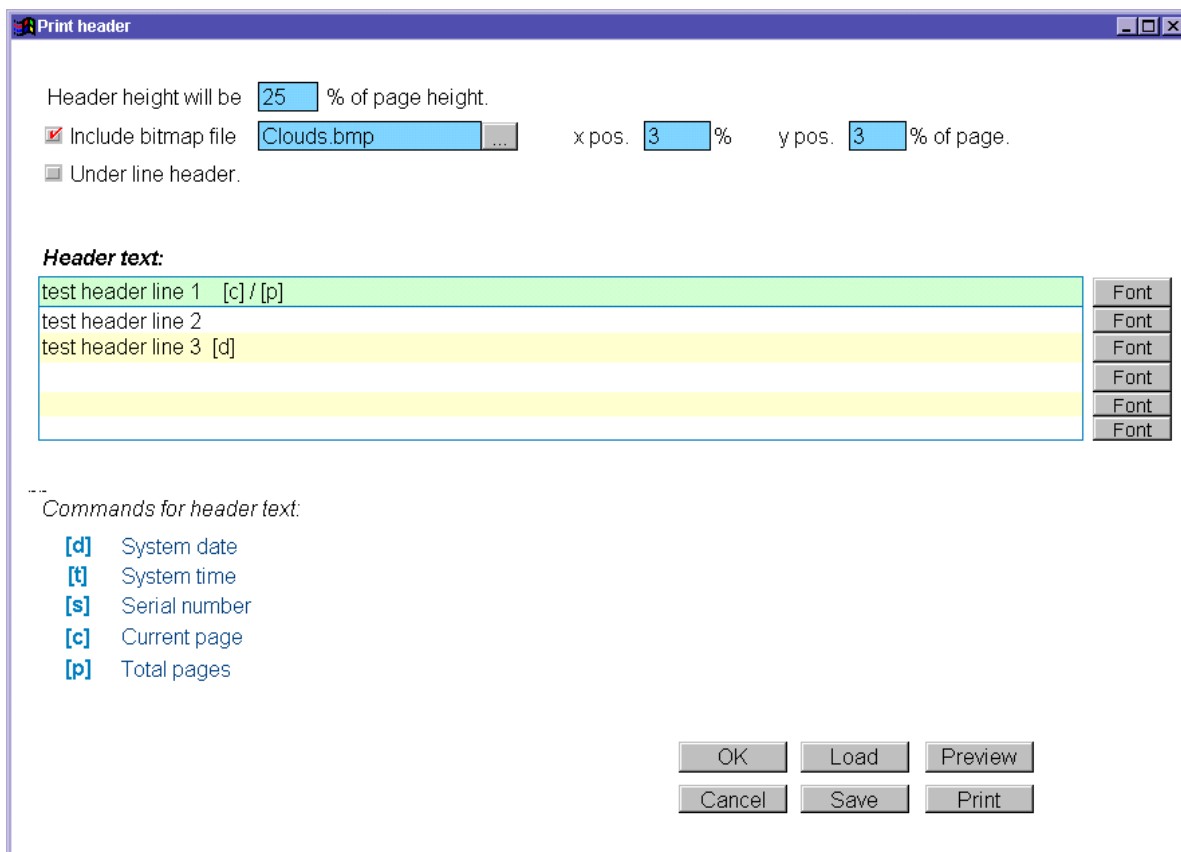

Fig. 72. Creating Header for printed documents

Our example will create header bellow.

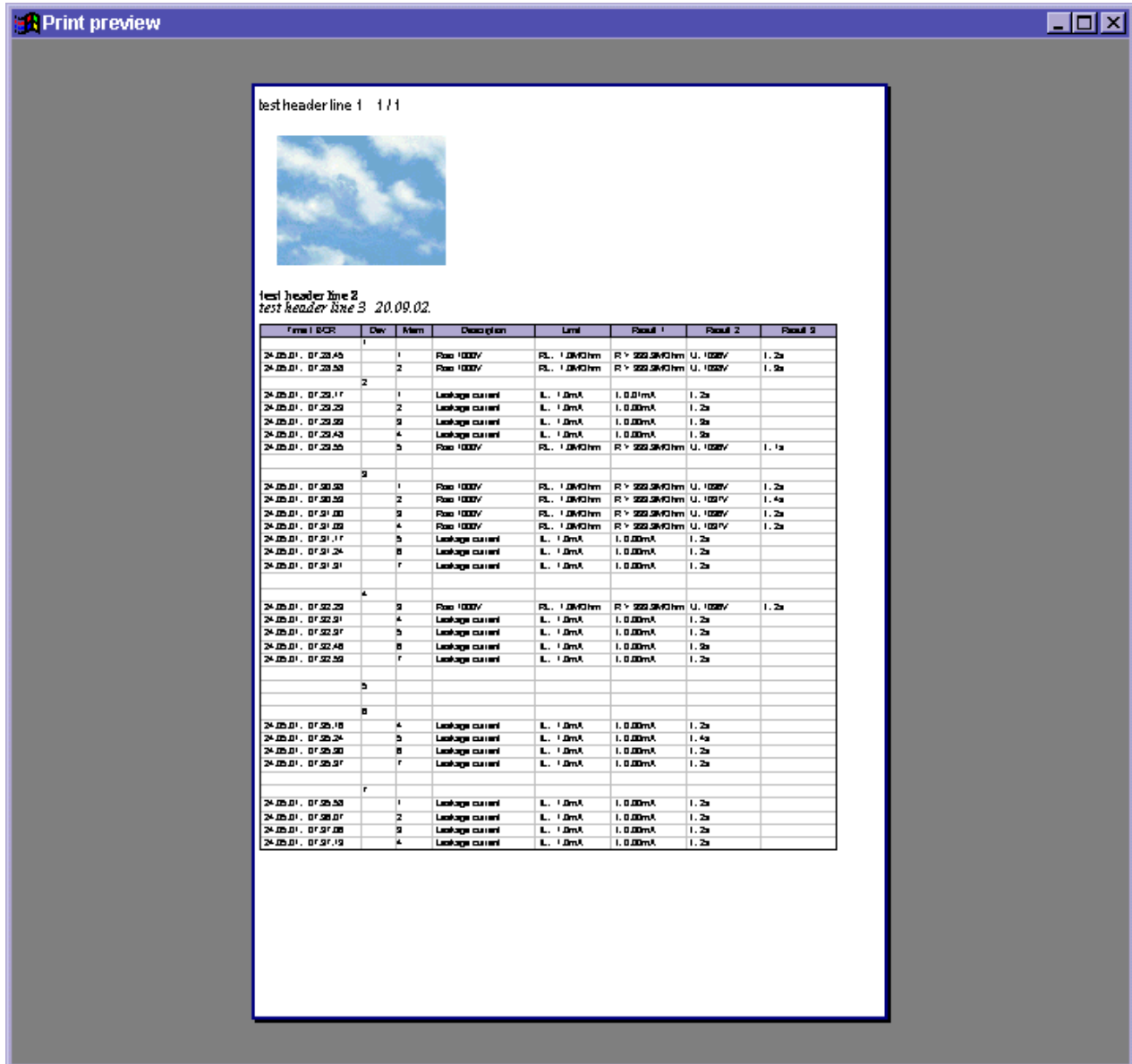

Fig. 73. PRINT preview

7.5.2 Print separately

Print separately function prints each measured device results to its own document. It is intended to print separate reports for each tested object (production line testing).



7.6. Header programming

Header programming

User string
User defined string

INSTRUMENT
HEADER
PROGRAMMING

Instrument model
CEMultiTester

Instrument type
MI2094

Firmware version
26

Serial number
00052601

Manufacturer
METREL

Manufacturer note

Send system time

Instrument time
05.07.00. 20:35:03

Baud rate (BCP)
2400

Baud rate (RS232)
19200

Read Send Close

Fig. 74. Header programming window

This window represents info window for your instrument (called header). To see instrument header the instrument has to be connected to PC.

User can change “User string” (max 48 characters), send system time (time and date set on the PC).

It is possible to change **User string** only in this way. Instrument time and date or baud rates can be edited directly on instrument without using software (see instruction in chapter 5.5. System configuration).

7.7. Sequence editor

Basic point of **Sequence editor** is displayed in chapter 4.10. AUTOTEST. The user will use **Sequence editor** to create desired sequences or to edit existing sequence on the instrument. Max. number of steps in one sequence is 32, including programmed pause, messages, barcode reader sequence and sound signals. Max. number depends on combination of included function in current example.

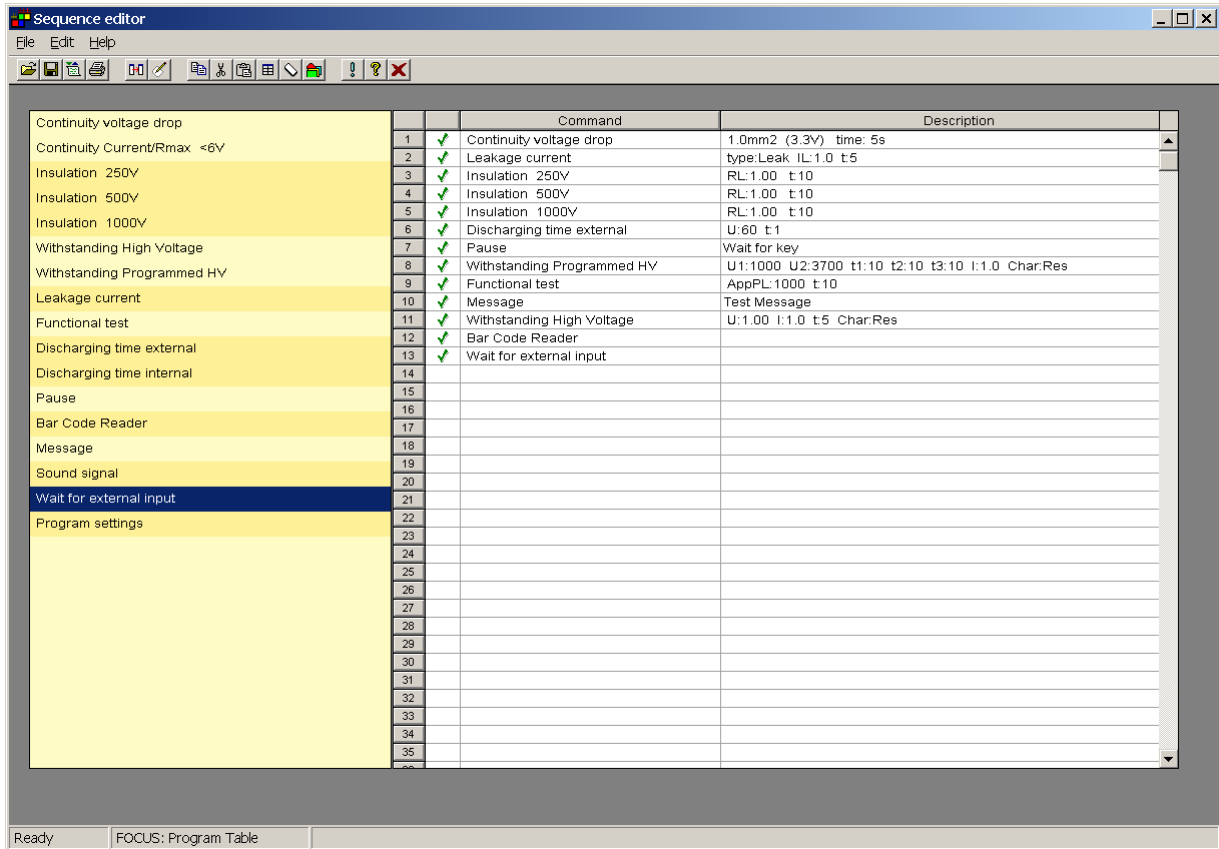
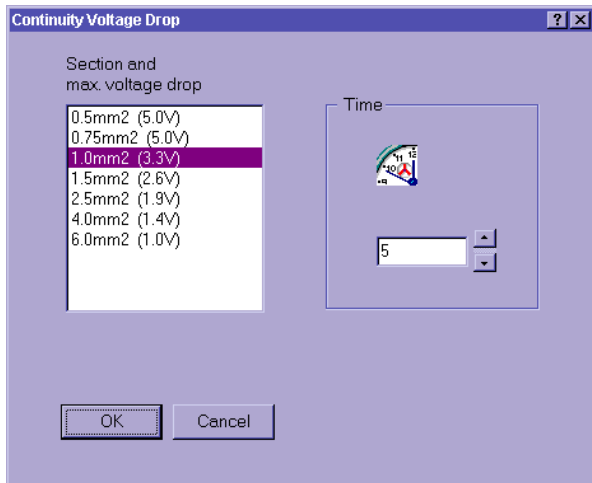

Fig. 75. Sequence editor window

Two main parts of Sequence editor are **Command table** and **Program table**. Command table contains all commands that can be executed on CE MultiTester.

User crates his sequence by selecting command one by one, and assigning them into program table using **Get command** key or by double clicking the desired command. For all selected commands limit values have to be set by using **Edit parameters** key.



Voltage drop Parameter window

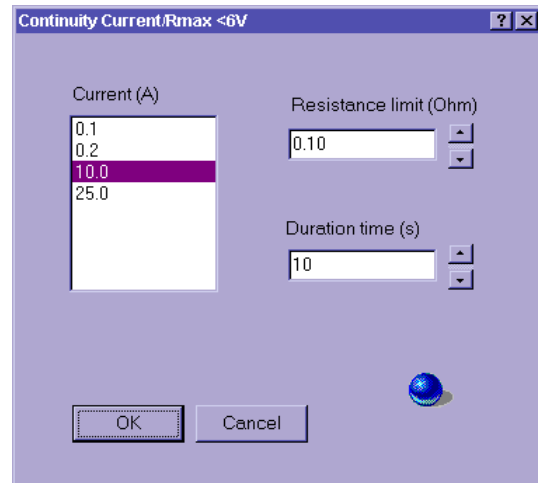

Continuity Current Parameter window

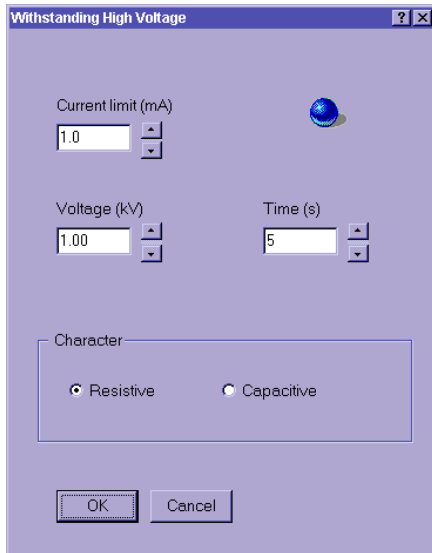

High Voltage Parameter window

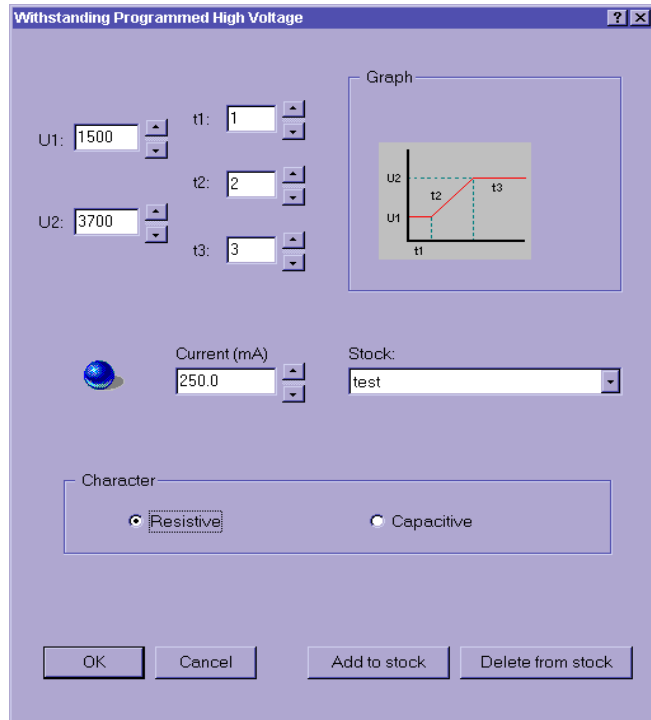

Programmed High Voltage Parameter window

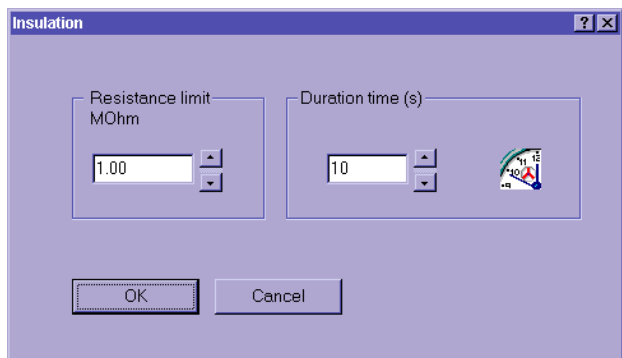

Insulation Parameter window

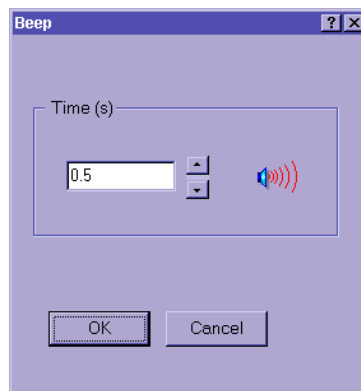

Sound Parameter window

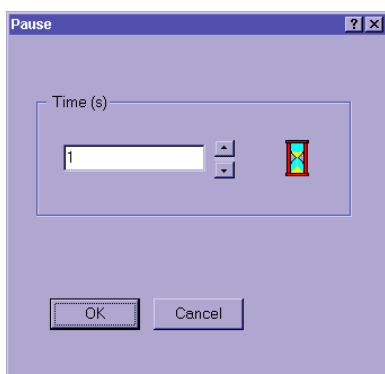

Pause Parameter window

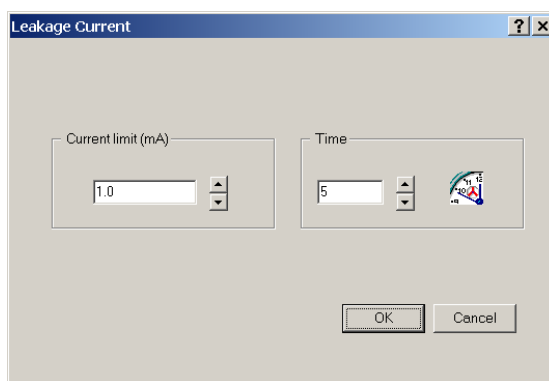

Leakage Current Parameter window

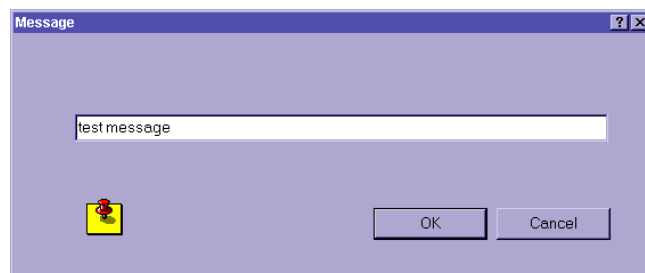

Message Parameter window

Fig. 76. Parameter windows

To set program name in **Command table** select **Program settings**.

In this dialog box user can also enable:

- pause (0 s – 5 s) between each test of the sequent,
- saving of measurement results,
- increment device number for successive sequence results,
- auto send each sequence results to PC (suitable for automate of production lines).
- auto repeat (autotest sequence is circularly repeated after defined Pause 0-5 sec).

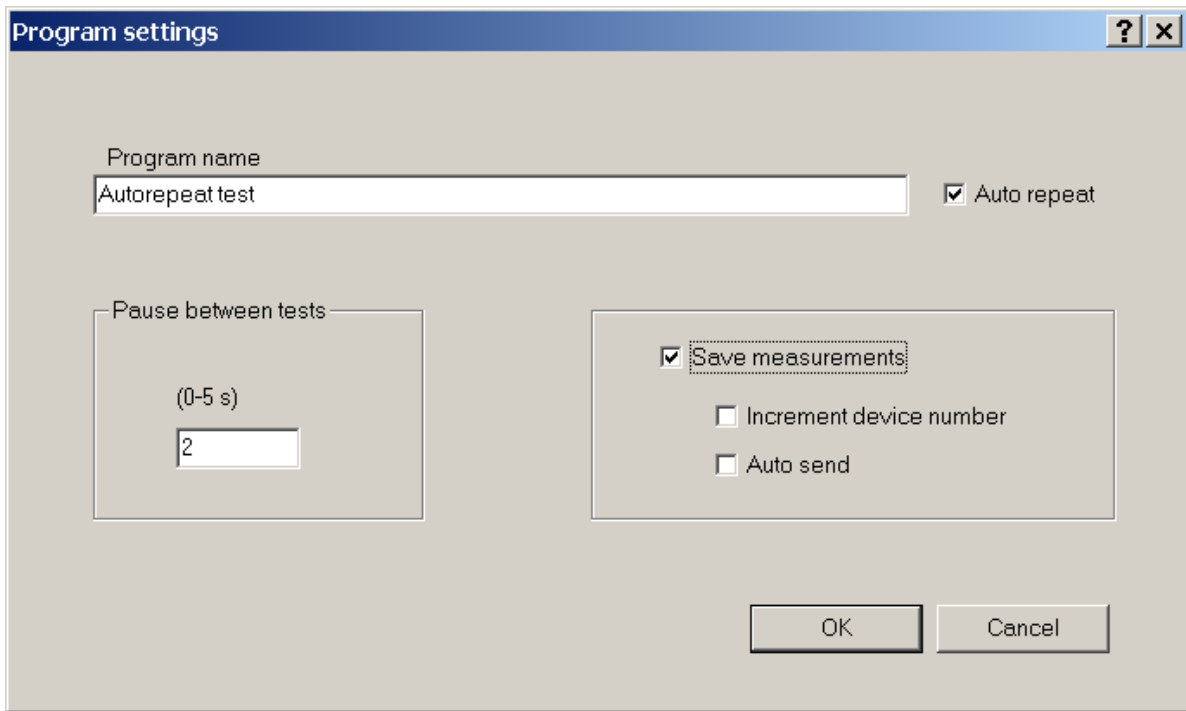

Fig. 77. Program name – definition window

Created sequence can be sent to CE MultiTester, and saved to disc with extension SQC.



	<p>List of instrument programs: Reads, delete and sends sequence to instrument. Shortcut key: Alt F + D</p>		<p>Clear row data: Clears only data, not whole row. Shortcut key: Alt S + P</p>
	<p>Get command: Copies selected command from command table to program table. Shortcut key: Alt F + O</p>		<p>Insert empty row: Inserts an empty row at selected row (for a new command). Shortcut key: Alt H</p>
	<p>Edit parameters: Set limits and other parameters for selected type of measurement. Shortcut key: Alt F + H</p>		

Table. 3. Fast access buttons

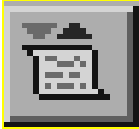
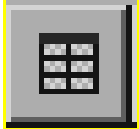
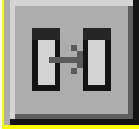