

GREYSTONE
ENERGY SYSTEMS INC

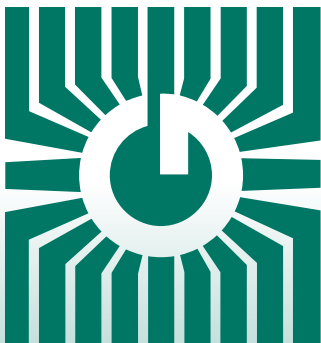

SOLID CORE CURRENT SENSOR CS-6XX Series



Precision Power control/sensing

FEATURES:

- Solid Core
- 0-5, 0-10 Vdc or 4-20 mA Output
- Selectable or Fixed Range Models
- Self-powered and Loop-powered Models
- Up to 200 amps Input Current
- Small Compact Size

*Peace of mind
through reliable
current monitoring*

GREYSTONE HAS AN **ISO 9001** REGISTERED QUALITY SYSTEM

AC CURRENT SENSORS

CS-650 Series

DESCRIPTION:

The CS-650 Series current sensors monitor line current for electrical loads such as pumps, conveyors, machine tools, or fans and output a 0-5 Vdc signal to represent the load current.

The CS-650 require no external power as they are totally powered by induction from the AC line being monitored.

The sensors are typically used to monitor motor operation and can be used to determine motor failure, belt loss, machine feed rates or tool wear.

SPECIFICATION:

Measurement Range.....	Up to 200 Amps - See ordering information
Maximum Input Current.....	CS-650-R1: 100 Amps Continuous CS-650-R2: 150 Amps Continuous CS-650-200: 250 Amps Continuous
Accuracy.....	± 2% FSO (5-100% of range)
Signal Output.....	0-5 Vdc
Sensor Power.....	Self-powered
Insulation Class.....	600 Vac, insulated conductors
Frequency.....	50/60 Hz
Response Time.....	200 mS Typical, 0-90 %
Output Load.....	1 MΩ typical
Loading Error.....	add 0.5% error with 100KΩ
Operating Temperature.....	-15 to 60 °C (5 to 140 °F)
Operating Humidity.....	5 to 90% RH non-condensing
Terminal Block.....	14 to 22 AWG
Dimensions.....	67 x 68.6 x 24.1 mm (2.65 x 2.7 x 0.95 in)
Sensor Aperture.....	20.3 mm (0.8 in)
Enclosure Material.....	ABS/PC, UL94 V-0
Agency Approvals.....	cULus Listed

FEATURES:

- No field adjustment necessary, factory calibrated
- Input / Output isolation via current transformer
- Solid-state reliability
- Small compact size
- Solid, reliable mounting method

PRODUCT ORDERING INFORMATION

MODEL	Output Signal
CS-650	0-5 Vdc, Self-powered

CODE	Sensing Range	Maximum Input Current
R1	0-10/20/50 Amps - Switch Selectable	100 Amps Continuous
R2	0-50/100/150 Amps - Switch Selectable	150 Amps Continuous
200	0-200 Amps	250 Amps Continuous

CS-650 - R1	Current Sensor, 0-5 Vdc Output, 0-10/20/50 Amp Input
--------------------	---

Greystone Energy Systems, Inc. reserves the right to make design modifications without prior notice.

AC CURRENT SENSORS CS-651 Series

DESCRIPTION:

The CS-651 Series current sensors monitor line current for electrical loads such as pumps, conveyors, machine tools, or fans and output a 0-10 Vdc signal to represent the load current.

The CS-651 require no external power as they are totally powered by induction from the AC line being monitored.

The sensors are typically used to monitor motor operation and can be used to determine motor failure, belt loss, machine feed rates or tool wear.

SPECIFICATION:

Measurement Range.....	Up to 200 Amps - See ordering information
Maximum Input Current.....	CS-651-R1: 100 Amps Continuous CS-651-100: 150 Amps Continuous CS-651-200: 225 Amps Continuous
Accuracy.....	± 2% FSO (5-100% of range)
Signal Output.....	0-10 Vdc
Sensor Power.....	Self-powered
Insulation Class.....	600 Vac, insulated conductors
Frequency.....	50/60 Hz
Response Time.....	200 mS Typical, 0-90 %
Output Load.....	1 MΩ typical
Loading Error.....	add 0.5% error with 100KΩ
Operating Temperature.....	-15 to 60 °C (5 to 140 °F)
Operating Humidity.....	5 to 90% RH non-condensing
Terminal Block.....	14 to 22 AWG
Dimensions.....	67 x 68.6 x 24.1 mm 2.65 x 2.7 x 0.95 in)
Sensor Aperture.....	20.3 mm (0.8 in)
Enclosure Material.....	ABS/PC, UL94 V-0
Agency Approvals.....	cULus Listed

FEATURES:

- No field adjustment necessary, factory calibrated
- Input / Output isolation via current transformer
- Solid-state reliability
- Small compact size
- Solid, reliable mounting method

PRODUCT ORDERING INFORMATION

MODEL	Output Signal
CS-651	0-10 Vdc, Self-powered

CODE	Sensing Range	Maximum Input Current
R1	0-10/20/50 Amps - Switch Selectable	100 Amps Continuous
100	0-100 Amps	150 Amps Continuous
200	0-200 Amps	225 Amps Continuous

CS-651 - R1	Current Sensor, 0-10 Vdc Output, 0-10/20/50 Amp Input
--------------------	--

Greystone Energy Systems, Inc. reserves the right to make design modifications without prior notice.

AC CURRENT SENSORS

CS-652 Series

DESCRIPTION:

The CS-652 Series current sensors monitor line current for electrical loads such as pumps, conveyors, machine tools, or fans and output a 4-20 mA Vdc signal to represent the load current.

The CS-652 is loop-powered and requires a 15-30 Vdc supply.

The sensors are typically used to monitor motor operation and can be used to determine motor failure, belt loss, machine feed rates or tool wear.

SPECIFICATION:

Measurement Range.....	Up to 200 Amps - See ordering information
Maximum Input Current.....	CS-652-R1: 100 Amps Continuous CS-652-R2: 150 Amps Continuous CS-652-200: 250 Amps Continuous
Accuracy.....	± 2% FSO (5-100% of range)
Signal Output.....	4-20 mA
Sensor Power.....	15 to 30 Vdc (Loop-powered)
Insulation Class.....	600 Vac, insulated conductors
Frequency.....	50/60 Hz
Response Time.....	250 mS Typical, 0-90 %
Output Load.....	250 Ω typical
Maximum Load.....	<600 Ω at 24 Vdc
Operating Temperature.....	-15 to 60 °C (5 to 140 °F)
Operating Humidity.....	5 to 90% RH non-condensing
Terminal Block.....	14 to 22 AWG
Dimensions.....	67 x 68.6 x 24.1 mm (2.65 x 2.7 x 0.95 in)
Sensor Aperture.....	20.3 mm (0.8 in)
Enclosure Material.....	ABS/PC, UL94 V-0
Agency Approvals.....	cULus Listed

FEATURES:

- No field adjustment necessary, factory calibrated
- Average measurement is equivalent to True RMS for pure sine waves
- Input / Output isolation via current transformer
- Solid-state reliability
- Small compact size
- Solid, reliable mounting method

PRODUCT ORDERING INFORMATION

MODEL	Output Signal
CS-652	4-20 mA , Loop-powered

CODE	Sensing Range	Maximum Input Current
R1	0-10/20/50 Amps - Switch Selectable	100 Amps Continuous
R2	0-50/100/150 Amps - Switch Selectable	150 Amps Continuous
200	0-200 Amps	250 Amps Continuous

CS-652 - R1	Current Sensor, 4-20 mA Output, 0-10/20/50 Amp Input
--------------------	---

Greystone Energy Systems, Inc. reserves the right to make design modifications without prior notice.

AC CURRENT SENSORS CS-675 Series

DESCRIPTION:

The CS-675 Series current sensors monitor line current for electrical loads such as pumps, conveyors, machine tools, or fans and output an analog signal to represent the load current. The CS-675 is loop-powered and requires 15 to 30 Vdc to power the device

The CS-675 series features True RMS current measurement suitable to measure complex waveforms such as those found in VFD controlled loads. They are also suitable for accurate measurement of phase angled controlled or time proportional SCR controlled load currents. The CS-675 Series contain a precision RMS-to-DC converter circuit which will measure load current accurately for complex, distorted or noisy waveforms as opposed to "average reading" devices that will only accurately measure pure sine waveforms .

SPECIFICATION:

Measurement Range	See Ordering Information below
Maximum Input Current	See Ordering Information below
Accuracy	± 2% FSO (5-100% of range)
Signal Output	4-20 mA
Sensor Power	15 to 30 Vdc (Loop -powered)
Insulation Class	600 Vac, insulated conductors
Frequency	20-400 Hz
Response Time	500 mS Typical, 0-90 %
Output Load	250 Ω typical
Maximum Load	>600 Ω Max. @ 24 Vdc
Operating Temperature	-15 to 50 °C (5 to 122 °F)
Operating Humidity	5 to 90% RH non-condensing
Terminal Block	14 to 22 AWG
Dimensions	66 x 67.3 x 24.9 mm (2.6 x 2.65 x 0.98 in)
Sensor Aperture	0.8 in (20.3 mm)
Enclosure Material	ABS/PC, UL94 V-0
Agency Approvals	cULus Listed

FEATURES:

- True RMS for complex waves
- Input / Output isolation via current transformer
- Solid-state reliability
- Small compact size
- Solid, reliable mounting method

PRODUCT ORDERING INFORMATION

MODEL	Output Signal
CS-675	4-20 mA, Loop-powered

CODE	Sensing Range	Maximum Input Current
2	0-2 Amps	10 Amps Continuous
5	0-5 Amps	15 Amps Continuous
R1	0-10/20/50 Amps - Jumper Selectable	100 Amps Continuous
R2	0-50/100/150 Amps - Jumper Selectable	150 Amps Continuous
200	0-200 Amps	250 Amps Continuous

CS-675 - R1	Current Sensor, 4-20mA Output, 0-10/20/50 Amp Input
--------------------	--

Greystone Energy Systems, Inc. reserves the right to make design modifications without prior notice.

DIMENSIONS

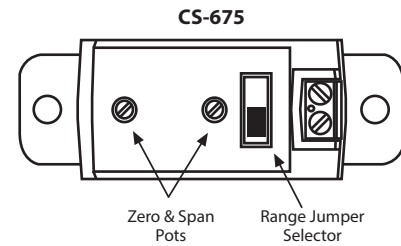
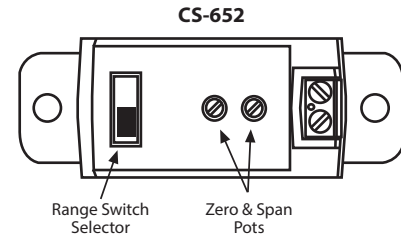
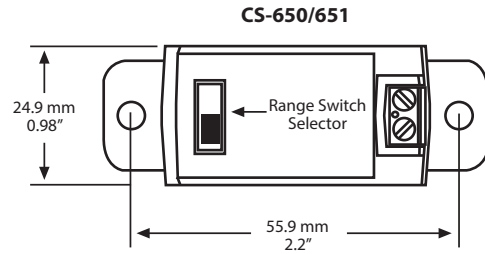
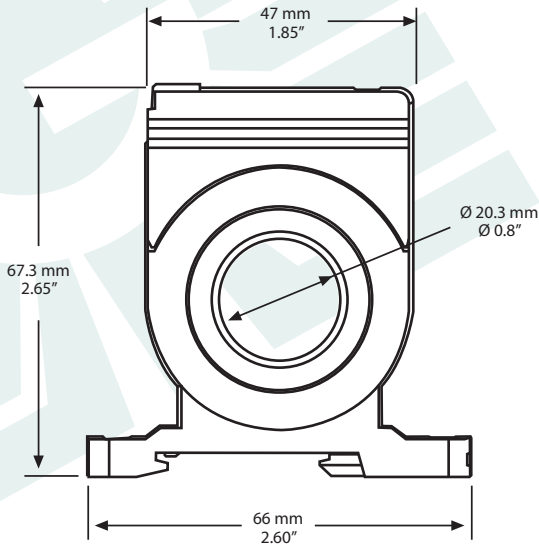

NOTE: The range switch/jumper is not applicable for models with 1 fixed range.

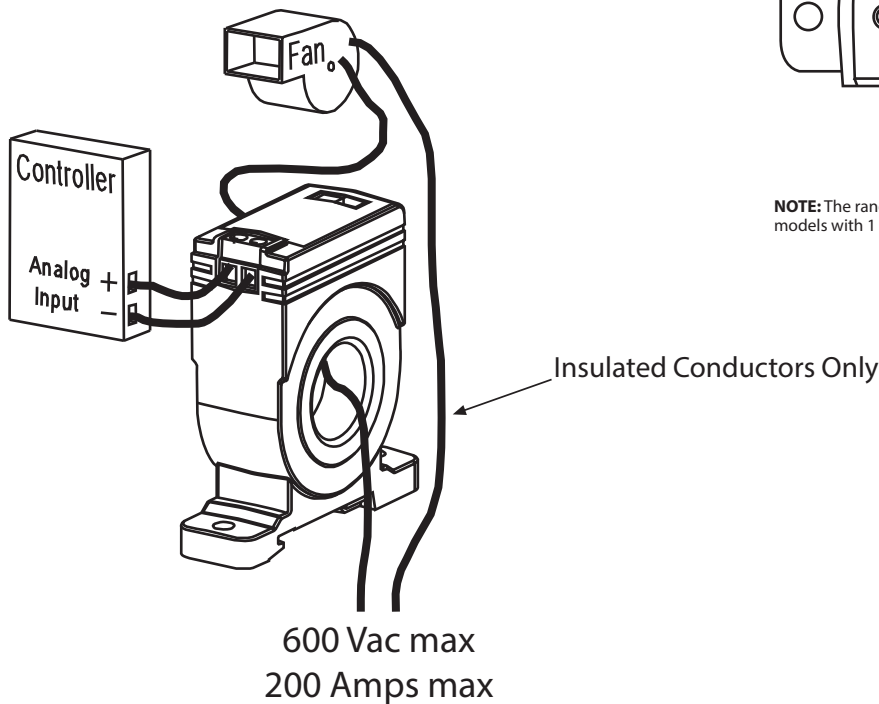

GREYSTONE

ENERGY SYSTEMS INC

Greystone Energy Systems, Inc.
 150 English Drive, Moncton,
 New Brunswick, Canada E1E 4G7
 (506) 853-3057 Fax: (506) 853-6014
 North America: 1-800-561-5611
 e-mail: mail@greystoneenergy.com
 www.greystoneenergy.com



RoHS
COMPLIANT



Greystone Energy Systems Inc. is one of North America's largest ISO registered manufacturers of HVAC/R sensors and transmitters for Building Automation Management Systems.

We have conscientiously established a worldwide reputation as an industry leader by maintaining leading-edge design technology, prompt technical support, and a commitment to on-time deliveries. We take pride in our Quality Management System which is ISO 9001 certified, assuring our customers of consistent product reliability.

GREYSTONE HAS AN **ISO 9001** REGISTERED QUALITY SYSTEM